

**PENN TOWNSHIP  
BUTLER COUNTY**

**CONSTRUCTION STANDARDS**

**PREPARED JULY 2017**

**RESOLUTION NO. 492**

Penn Township, Butler County, Pennsylvania

A RESOLUTION OF PENN TOWNSHIP, BUTLER COUNTY, PENNSYLVANIA  
APPROVING CONSTRUCTION STANDARDS

WHEREAS, The Board of Supervisors hired HRG Engineers, Inc. to compile a Construction Standards book to assist the Penn Township Subdivision Ordinance for appropriate development , and

WHEREAS, the Municipal Staff and Penn Township Planning Commission reviewed the Construction book for completeness, and

WHEREAS, the construction book follows engineering design standards, and

WHEREAS, the Construction Standards book is attached, and

NOW, THEREFORE, BE IT RESOLVED that Penn Board of Supervisors, Butler County, Pennsylvania adopts the Penn Township Master Plan.

RESOLVED this 10<sup>th</sup> day of July., 2018.

PENN TOWNSHIP

BOARD OF SUPERVISORS

By 

Chairman

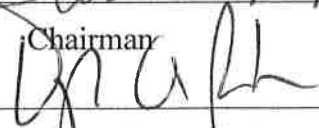
By 

Vice - Chairman

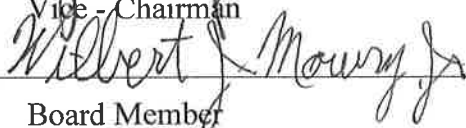
By 

Board Member

Attest:

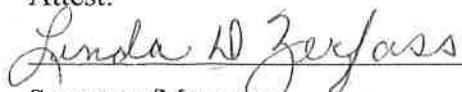
  
Secretary/Manager

SD-001	TYPICAL SIDEWALK DETAIL
SD-002	TYPICAL TRAIL DETAIL
SD-003	RESIDENTIAL DRIVEWAY DETAIL WITH WEDGE CURB
SD-004	RESIDENTIAL DRIVEWAY DETAIL WITH CONCRETE CURB
SD-005	RESIDENTIAL AND MINIMUM DRIVEWAY USE DRIVEWAY GRADE REQUIREMENTS
SD-006	DRIVEWAY SITE DISTANCE
SD-007	FORMULA SITE DISTANCE TABLES
SD-008	TYPICAL BITUMINOUS WEDGE CURB DETAIL
SD-009	TYPICAL CONCRETE CURB DETAIL
SD-010	TYPICAL CONCRETE MOUNTABLE CURB DETAIL
SD-011	TYPICAL CURB RAMP DETAIL
SD-012	TYPICAL CONCRETE MEDIAN
SD-013	TYPICAL COLLECTOR DRIVEWAY
SD-014	TYPICAL PUBLIC STREET DETAIL
SD-015	SUBSURFACE DRAIN (PAVEMENT BASE DRAIN) DETAIL
SD-016	TYPICAL PARKING LOT PAVING DETAIL
SD-017	TYPICAL FDR FOR RESIDENTIAL ROADS
SD-018	TYPICAL AND OFFSET CUL-DE-SAC DETAILS
SD-019	TEMPORARY CUL-DE-SAC DETAILS
SD-020	TYPICAL DETAIL FOR REPAIR OF PAVED STREET
SD-021	TYPICAL DETAIL FOR REPAIR OF STREET WITH CONCRETE BASE
SD-022	TYPICAL STORM SEWER TRENCH DETAIL - IMPERVIOUS AREA
SD-023	TYPICAL STORM SEWER TRENCH DETAIL - PERMEABLE AREA
SD-024	TYPICAL STORM SEWER TRENCH DETAIL - DEPTHS EXCEEDING 8FT
SD-025	SUBSURFACE DRAIN DETAIL
SD-026	STORM MANHOLE DETAIL (TYPICAL SECTION)
SD-027	STANDARD MANHOLE FRAME & COVER
SD-028	TYPE C INLET DETAIL
SD-029	TYPICAL INLET DETAIL
SD-030	TYPICAL CONCRETE END WALL FOR 15" - 24" DIA PIPES
SD-031	TYPICAL CONCRETE END WALL FOR 36" - 72" DIA PIPES
SD-032	TUNNEL INSTALLATION DETAIL
SD-033	ROCK SUMP DETAIL
SD-034	ROCK SUMP STORAGE CHART
SD-035	REFORESTATION DETAIL
SD-036	SURVEY MONUMENT DETAIL



## CONSTRUCTION STANDARDS INDEX

REVISIONS				DRAWING
NO.	DATE	NO.	DATE	
				<b>SD-000</b>

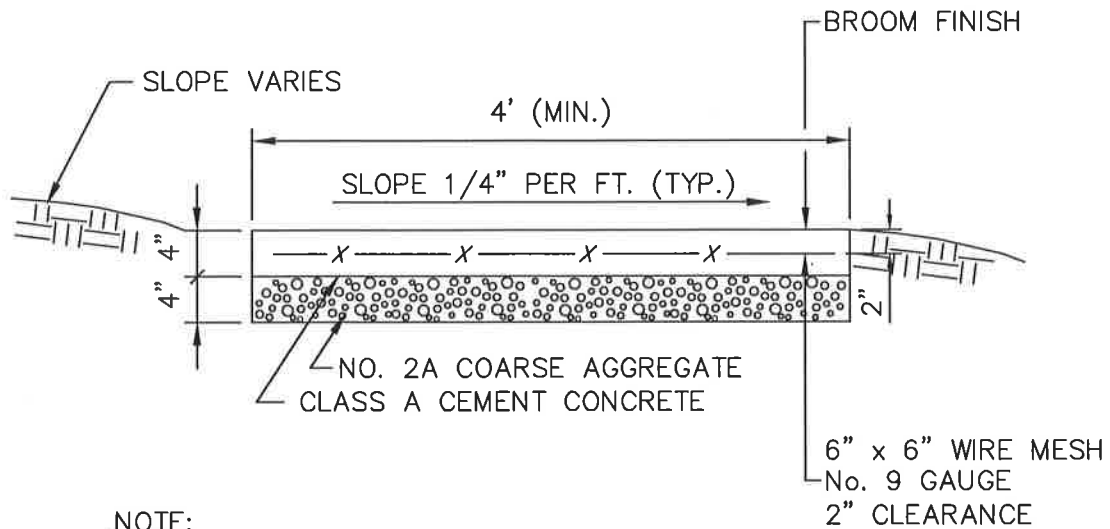

**NOTE:**

1. SIDEWALK TO HAVE MEDIUM BROOM FINISH PERPENDICULAR TO DIRECTION OF PEDESTRIAN TRAFFIC
2. CONSTRUCT IN ACCORDANCE WITH PENNDOT PUBLICATION 408.
3. CURB RAMPS SHALL BE PROVIDED IN ACCORDANCE WITH PENNDOT RC-67M, LATEST REVISION.

NOT TO SCALE



## TYPICAL SIDEWALK DETAIL

REVISIONS				DRAWING
NO.	DATE	NO.	DATE	
				<b>SD-001</b>

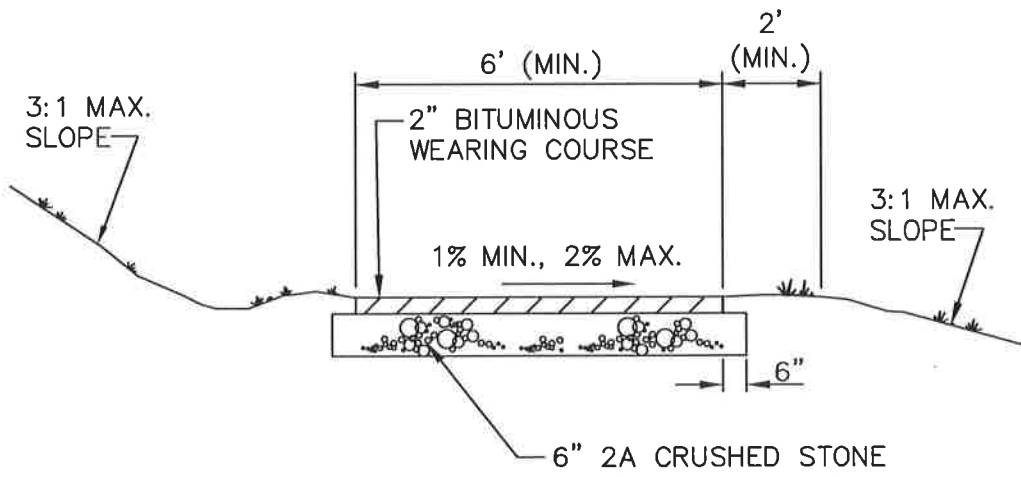

NOT TO SCALE



## TYPICAL TRAIL DETAIL

REVISIONS				DRAWING
NO.	DATE	NO.	DATE	
				<b>SD-002</b>

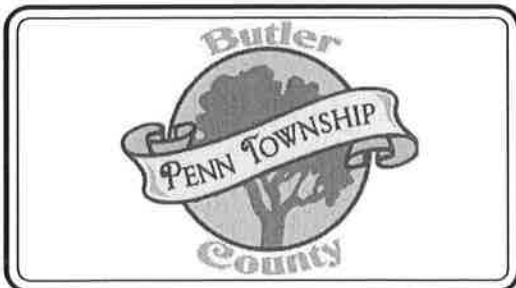
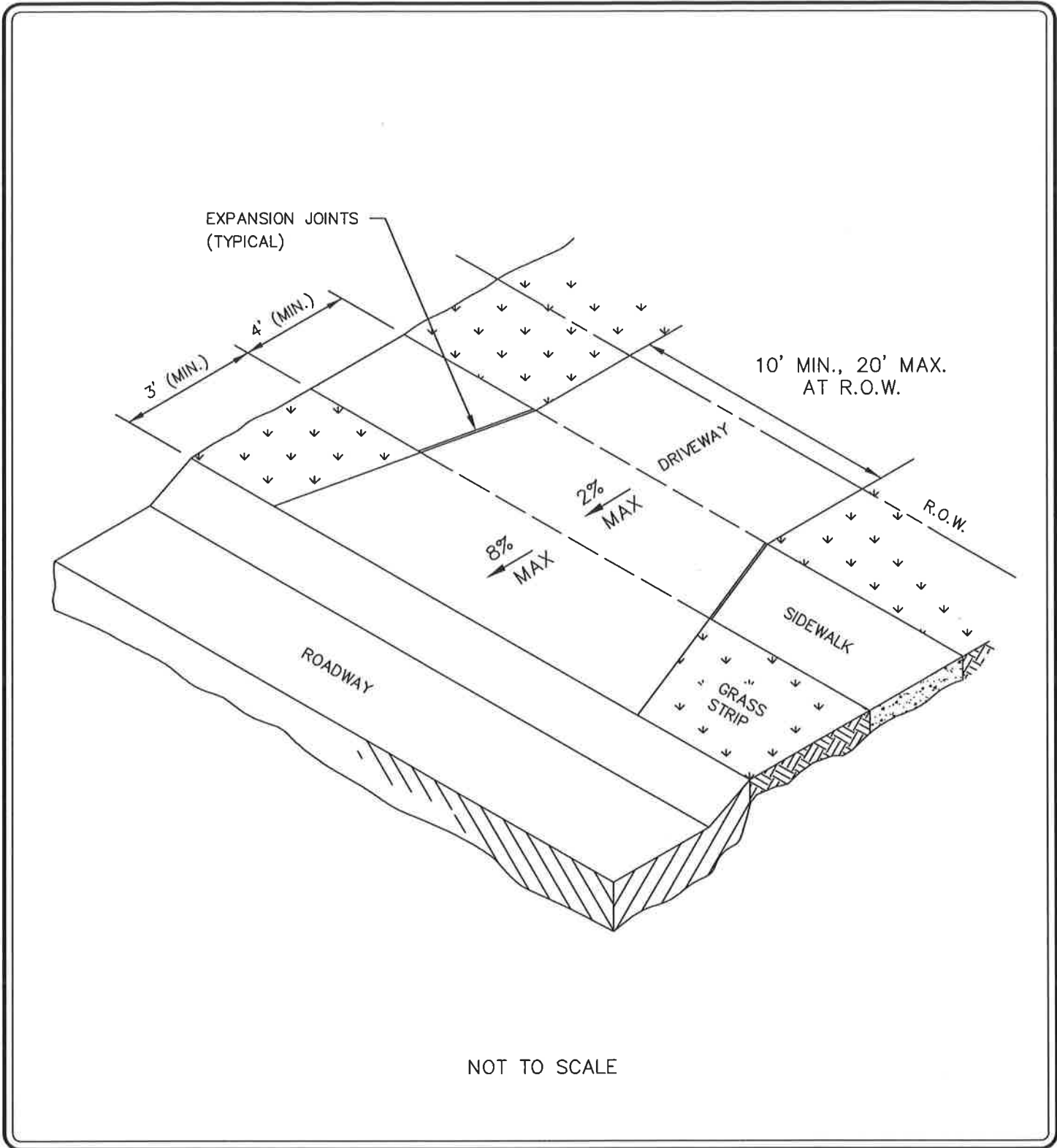

REVISIONS				DRAWING
NO.	DATE	NO.	DATE	
				<b>SD-003</b>

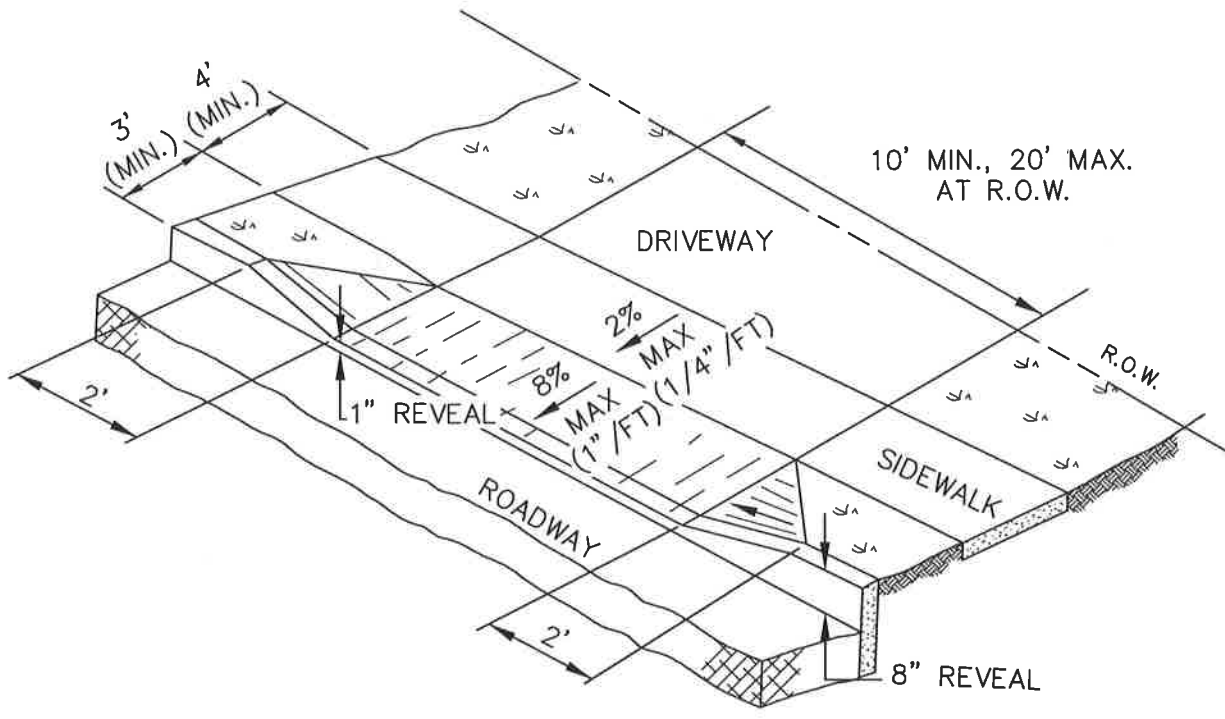

NOT TO SCALE



## RESIDENTIAL DRIVEWAY DETAIL WITH CONCRETE CURB

REVISIONS				DRAWING
NO.	DATE	NO.	DATE	
				<b>SD-004</b>

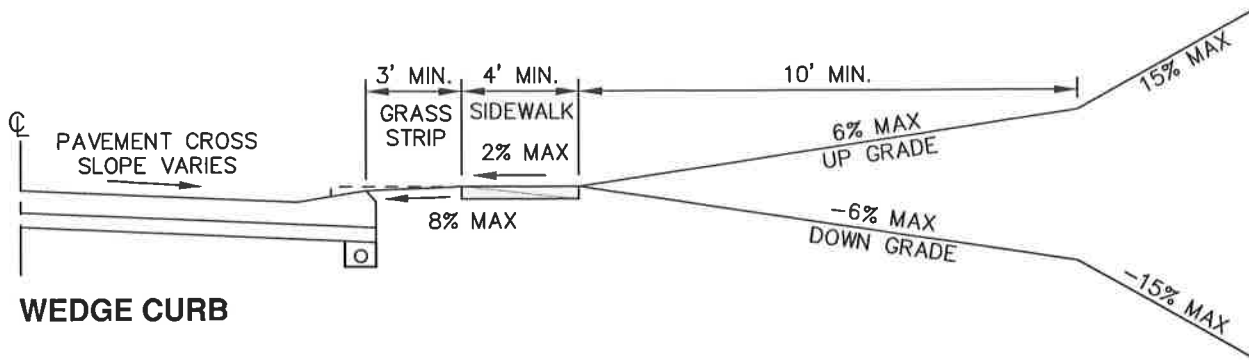

**WEDGE CURB**

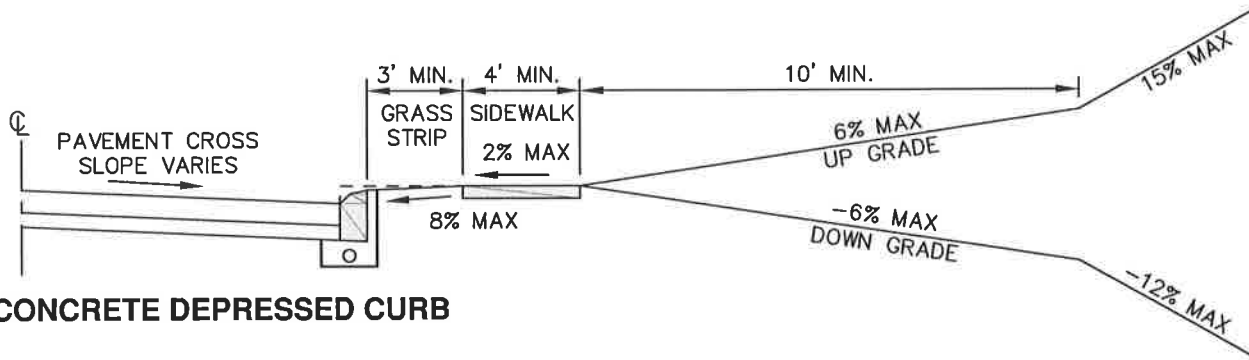

**CONCRETE DEPRESSED CURB**

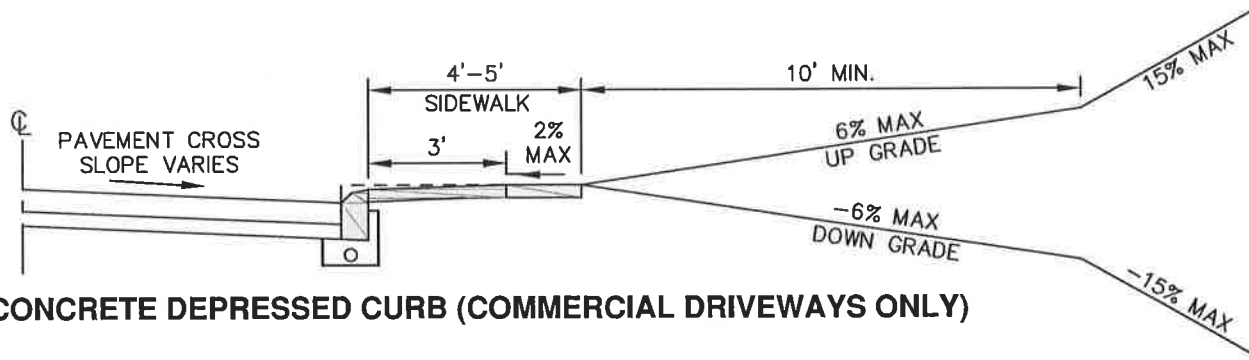

**CONCRETE DEPRESSED CURB (COMMERCIAL DRIVEWAYS ONLY)**

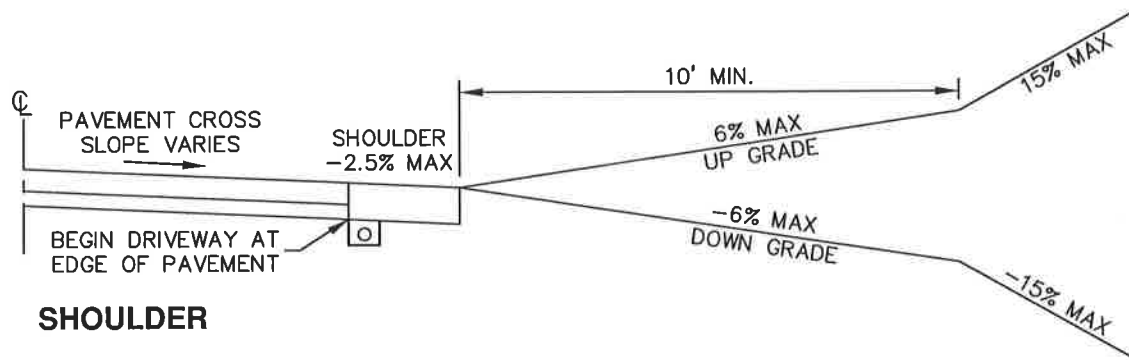

**SHOULDER**



**RESIDENTIAL AND MINIMUM DRIVEWAY  
USE DRIVEWAY GRADE REQUIREMENTS**

REVISIONS				DRAWING
NO.	DATE	NO.	DATE	
				<b>SD-005</b>



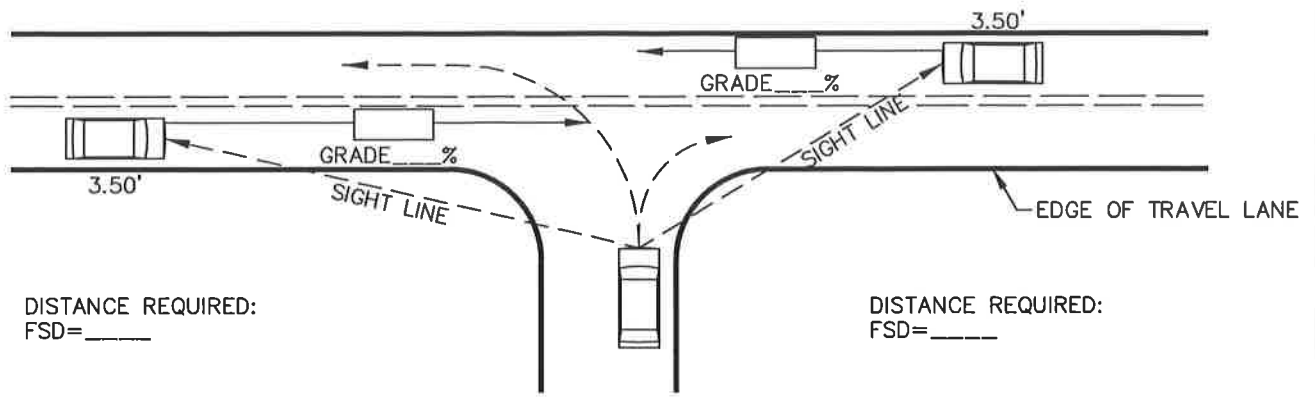

THE MAXIMUM LENGTH OF ROADWAY ALONG WHICH A DRIVER AT A DRIVEWAY LOCATION CAN CONTINUOUSLY SEE ANOTHER VEHICLE APPROACHING ON THE ROADWAY.

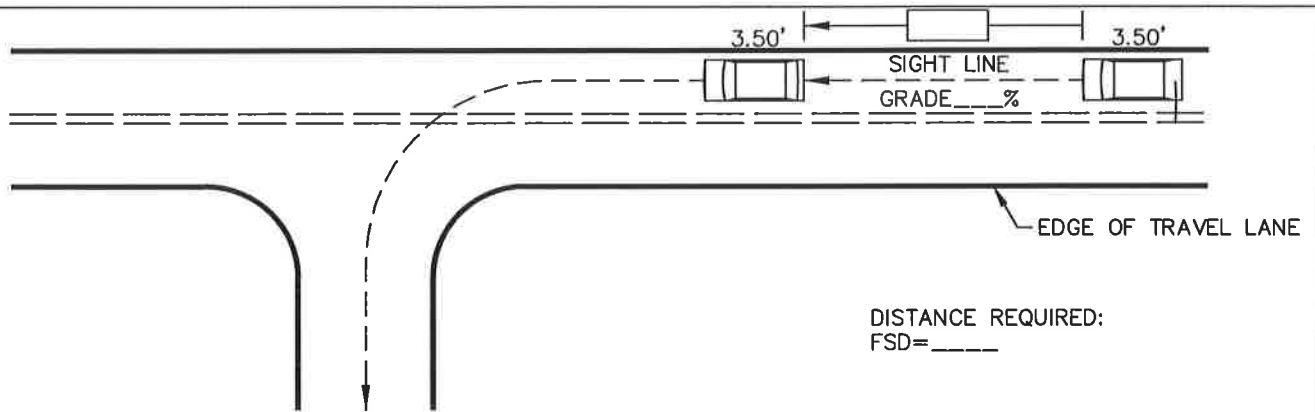

THE MAXIMUM LENGTH OF ROADWAY ALONG WHICH A DRIVER ON THE ROADWAY CAN CONTINUOUSLY SEE THE REAR OF A VEHICLE WHICH IS LOCATED IN THE DRIVERS TRAVEL LANE AND WHICH IS POSITIONED TO MAKE A LEFT TURN INTO A DRIVEWAY.

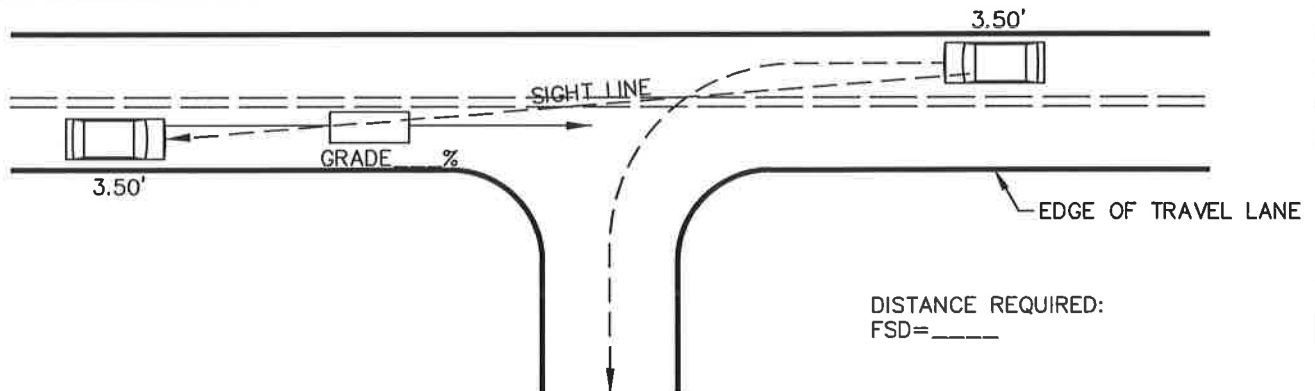

THE MAXIMUM LENGTH OF ROADWAY ALONG WHICH A DRIVER OF A VEHICLE INTENDING TO MAKE A LEFT TURN INTO A DRIVEWAY CAN CONTINUOUSLY SEE A VEHICLE APPROACHING FROM THE OPPOSITE DIRECTION.



## DRIVEWAY SITE DISTANCE

REVISIONS				DRAWING
NO.	DATE	NO.	DATE	
				<b>SD-006</b>

SPEED (V) (MPH)	AVERAGE GRADE (G) (PERCENT)										
	USE POSITIVE GRADES WHEN APPROACHING VEHICLE IS TRAVELING UP GRADE.										
	0.0	+1.0	+2.0	+3.0	+4.0	+5.0	+6.0	+7.0	+8.0	+9.0	+10.0
25	147	145	144	143	142	140	139	138	137	136	135
30	196	194	191	189	187	185	183	182	180	178	177
35	249	245	242	239	236	233	231	228	226	224	221
40	314	309	304	299	295	291	287	284	280	277	274
45	383	376	370	364	358	353	348	343	339	334	330
50	462	453	444	436	429	422	415	409	403	397	392
55	538	527	517	508	499	490	482	475	468	461	454

SPEED (V) (MPH)	AVERAGE GRADE (G) (PERCENT)										
	USE POSITIVE GRADES WHEN APPROACHING VEHICLE IS TRAVELING DOWN GRADE.										
	0.0	-1.0	-2.0	-3.0	-4.0	-5.0	-6.0	-7.0	-8.0	-9.0	-10.0
25	147	148	150	151	153	155	157	159	161	164	166
30	196	199	201	204	207	210	214	217	221	226	230
35	249	252	256	260	265	269	275	280	286	292	299
40	314	319	325	331	338	345	352	360	369	379	389
45	383	390	398	406	415	425	435	447	459	472	487
50	462	471	481	492	504	517	531	546	563	581	600
55	538	550	562	576	590	606	622	641	661	682	706



## FORMULA SITE DISTANCE TABLES

REVISIONS				DRAWING
NO.	DATE	NO.	DATE	
				<b>SD-007</b>

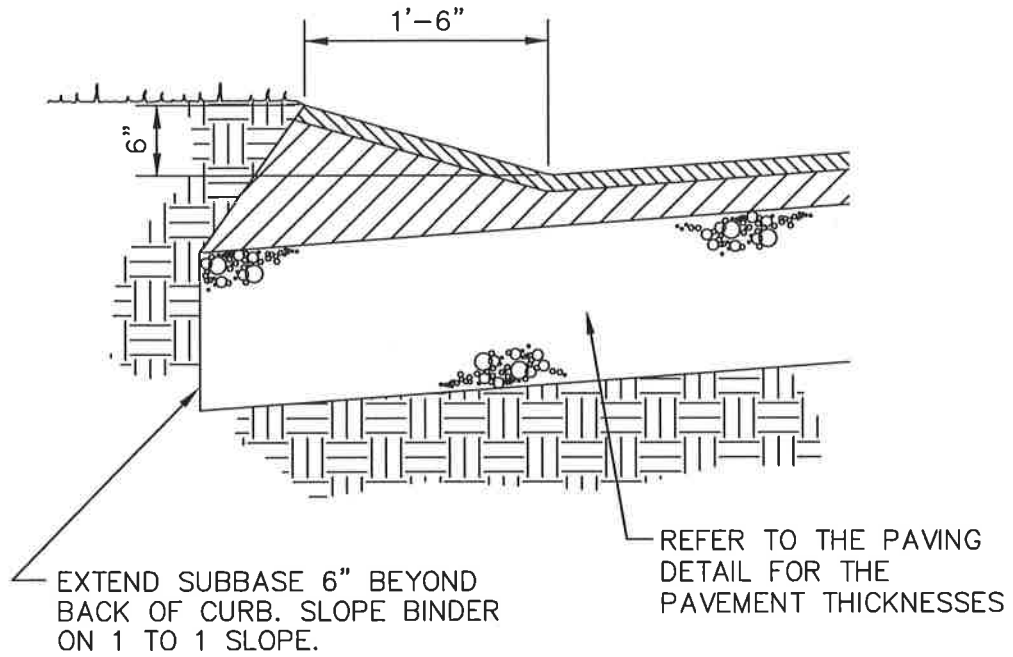

NOT TO SCALE



## TYPICAL BITUMINOUS WEDGE CURB DETAIL

REVISIONS				DRAWING
NO.	DATE	NO.	DATE	
				<b>SD-008</b>

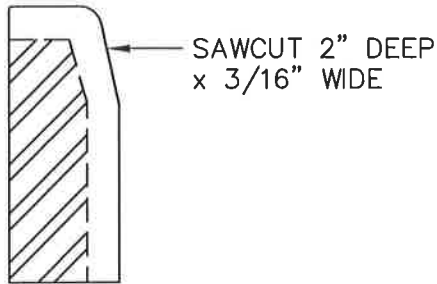

SAWCUT 2" DEEP  
x 3/16" WIDE

DETAIL 'A' CONTRACTION JOINT

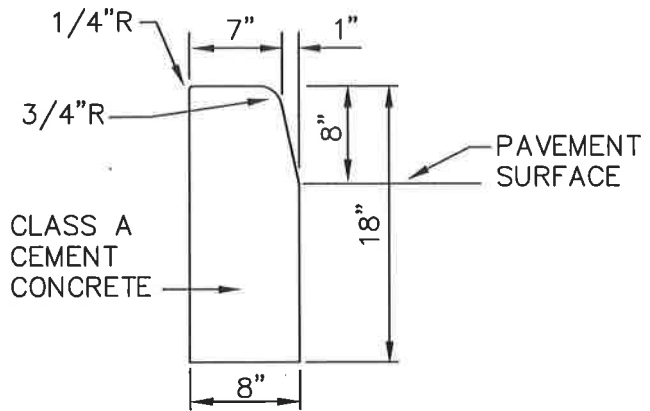

TYPICAL CROSS-SECTION

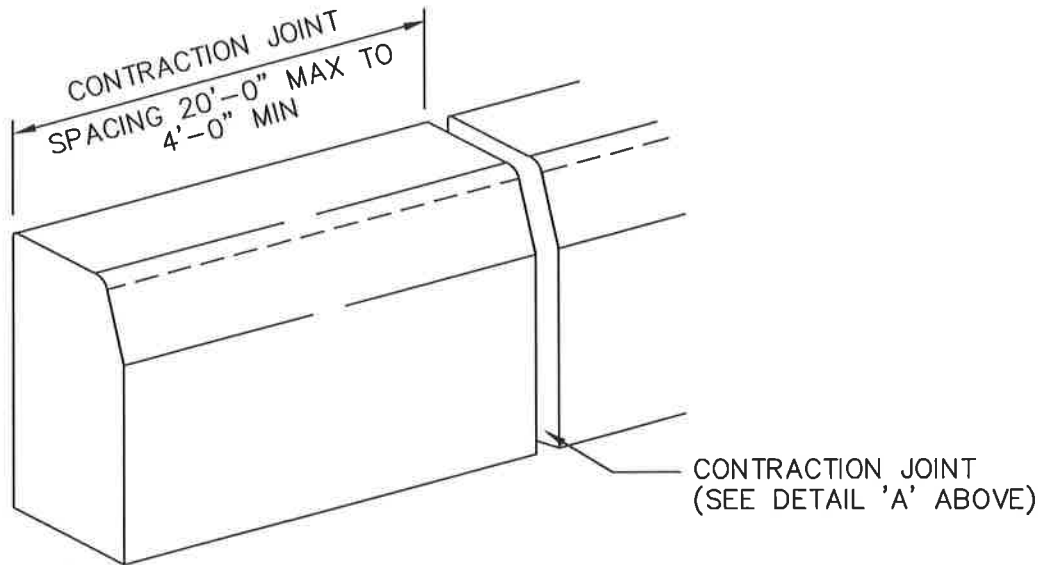

**NOTE:**

1. CONSTRUCT CURBING IN ACCORDANCE WITH PENNDOT SPECIFICATIONS PUBLICATION 408 AND ROADWAY CONSTRUCTION DRAWINGS (RC-64)

NOT TO SCALE



**TYPICAL CONCRETE CURB DETAIL**

REVISIONS				DRAWING
NO.	DATE	NO.	DATE	
				<b>SD-009</b>

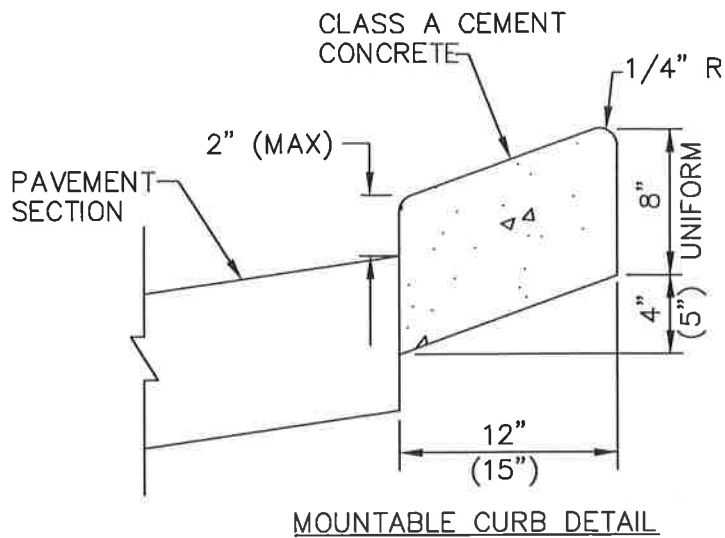

NOT TO SCALE

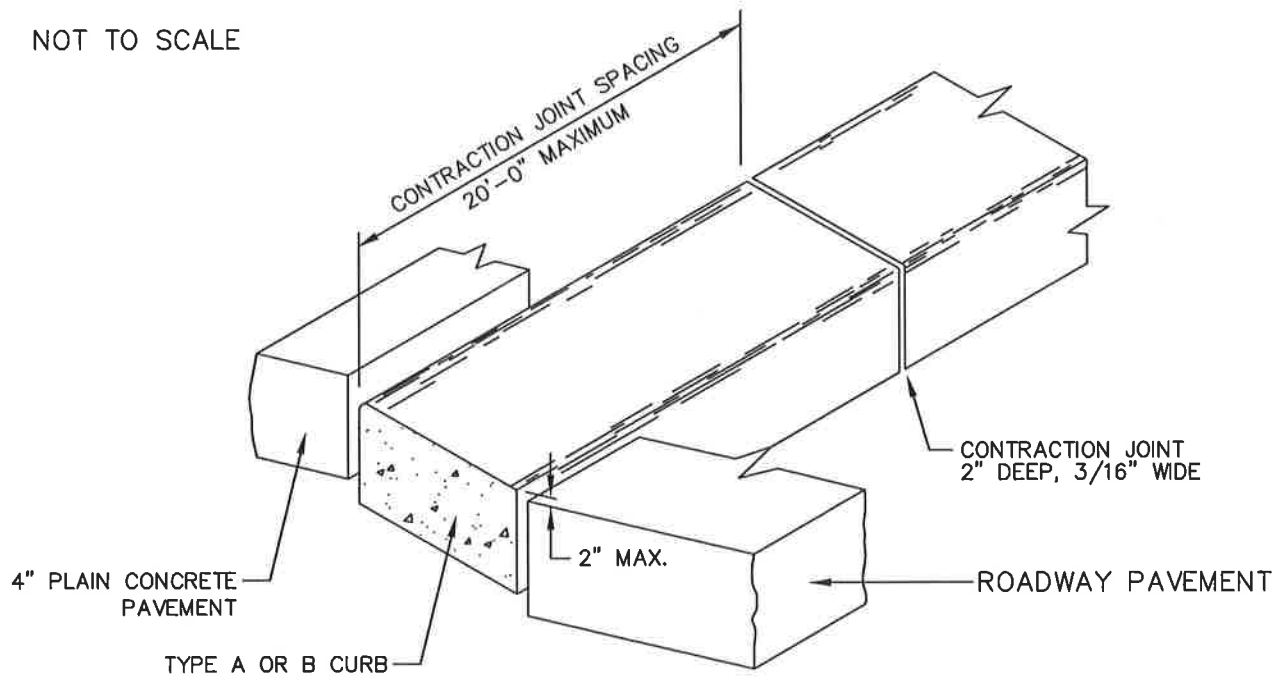

NOTES

1. CONSTRUCT IN ACCORDANCE WITH THE REQUIREMENTS OF PENNDOT RC-65.
2. TYPE A MOUNTABLE CURB DIMENSIONS SHOWN WITH TYPE B MOUNTABLE CURB SHOWN IN PARENTHESES.



**TYPICAL CONCRETE MOUNTABLE CURB DETAIL**

REVISIONS				DRAWING
NO.	DATE	NO.	DATE	SD-010

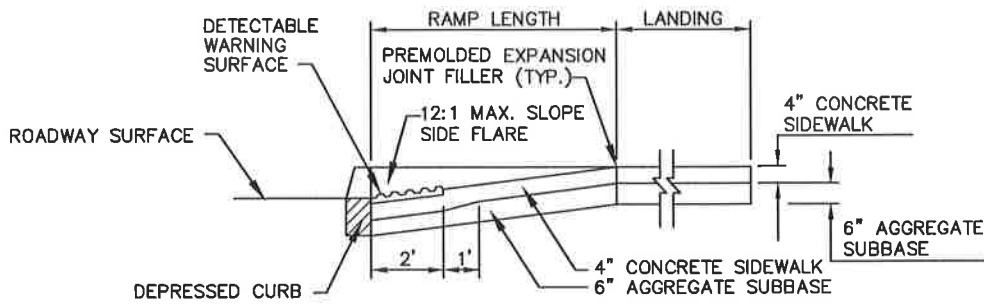

SECTION A-A

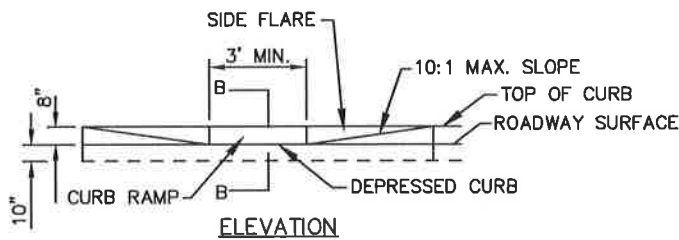

ELEVATION

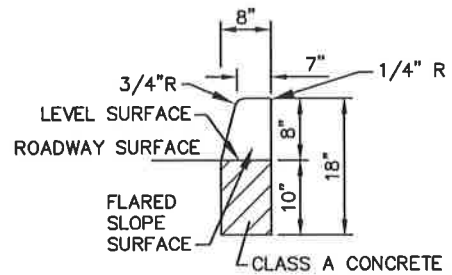

SECTION B-B  
DEPRESSED CURB

X IS EQUAL TO OR GREATER THAN 4'  
IF X IS LESS THAN 4', THEN MAKE THE  
SLOPE OF THE FLARED SIDES 12:1 MAX.

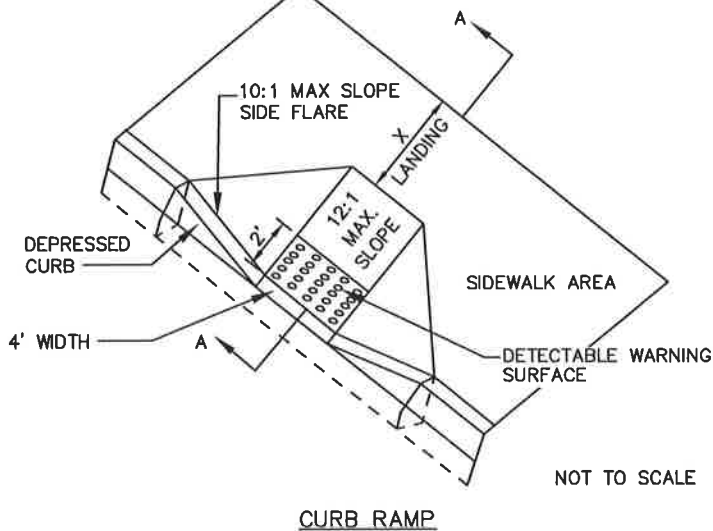

NOT TO SCALE

CURB RAMP

**NOTES:**

1. PROVIDE MATERIALS AND CONSTRUCTION MEETING THE REQUIREMENTS OF PENNDOT PUBLICATION 408 (CURRENT EDITION).
2. PROVIDE EXPANSION JOINT MATERIAL 1/2" THICK WHERE CURB RAMP ADJOINS ANY RIGID PAVEMENT, SIDEWALK OR STRUCTURE WITH THE TOP OF JOINT FILLER FLUSH WITH ADJACENT CONCRETE SURFACE.
3. SEAL JOINTS WITH AN APPROVED SEALING MATERIAL.
4. PROVIDE SLIP RESISTANT TEXTURE ON CURB RAMP BY COARSE BROOMING TRANSVERSE TO THE SLOPE OF THE RAMP. EXTEND TEXTURE THE FULL WIDTH AND LENGTH OF THE CURB RAMP INCLUDING FLARED SIDE RAMPS.
5. MODIFY CONSTRUCTION DETAILS TO ADAPT DIMENSIONS TO EXISTING CURB ALTERATIONS WHERE THE CURB IS LESS THAN STANDARD 8" HEIGHT.
6. CURB RAMP AND SIDE FLARE LENGTHS ARE VARIABLE AND BASED ON CURB HEIGHT AND THE SIDEWALK PITCH.
7. WHENEVER POSSIBLE, CONSTRUCT THE TRANSITION SLOPE FROM THE CURB RAMP AND FLARE SIDES TO ADJOINING SURFACES WITH A GRADUAL CURVE RATHER THAN AN ABRUPT ANGLE.
8. ALIGN DETECTABLE WARNING SURFACE ON A SQUARE GRID IN THE PREDOMINANT DIRECTION OF PEDESTRIAN TRAVEL.
9. PROVIDE DETECTABLE WARNING SURFACES THAT CONTRAST VISUALLY WITH ADJACENT WALKWAY SURFACES, EITHER LIGHT-ON-DARK OR DARK-ON-LIGHT FOR THE FULL WIDTH OF RAMP.
10. NOWHERE SHALL THE CROSS SLOPE OF THE RAMPS ACCESSIBLE ROUTE EXCEED 2%.
11. CONSTRUCT RAMP AND FLARE SLOPES WITH THE FLATTEST SLOPE POSSIBLE. THE SLOPES INDICATED IN THE DETAILS SHOW THE MAX SLOPE ALLOWABLE.

REFERENCE RC-67 - PENNDOT PUBLICATION 72



## TYPICAL CURB RAMP DETAIL

REVISIONS				DRAWING
NO.	DATE	NO.	DATE	
				<b>SD-011</b>

CONSTRUCTION JOINTS

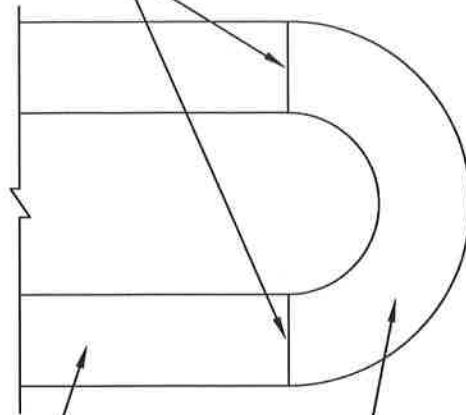

TYPE A CONCRETE  
MOUNTABLE CURB

END DETAIL

TYPE A OR B  
MOUNTABLE CURB  
(SEE DETAIL)

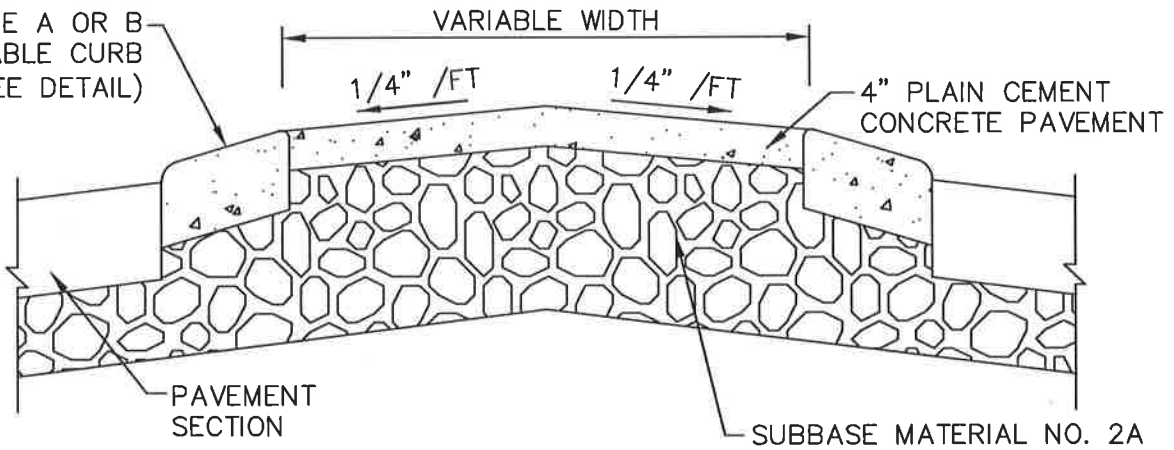

SECTION

NOTE:

1. CONSTRUCT IN ACCORDANCE WITH THE REQUIREMENTS OF PENNDOT RC-65.

NOT TO SCALE



## TYPICAL CONCRETE MEDIAN

REVISIONS				DRAWING
NO.	DATE	NO.	DATE	
				<b>SD-012</b>

CARTWAY WIDTH  
 ONE LANE = 16 FEET  
 TWO LANE = 24 FEET  
 THREE LANE = 36 FEET

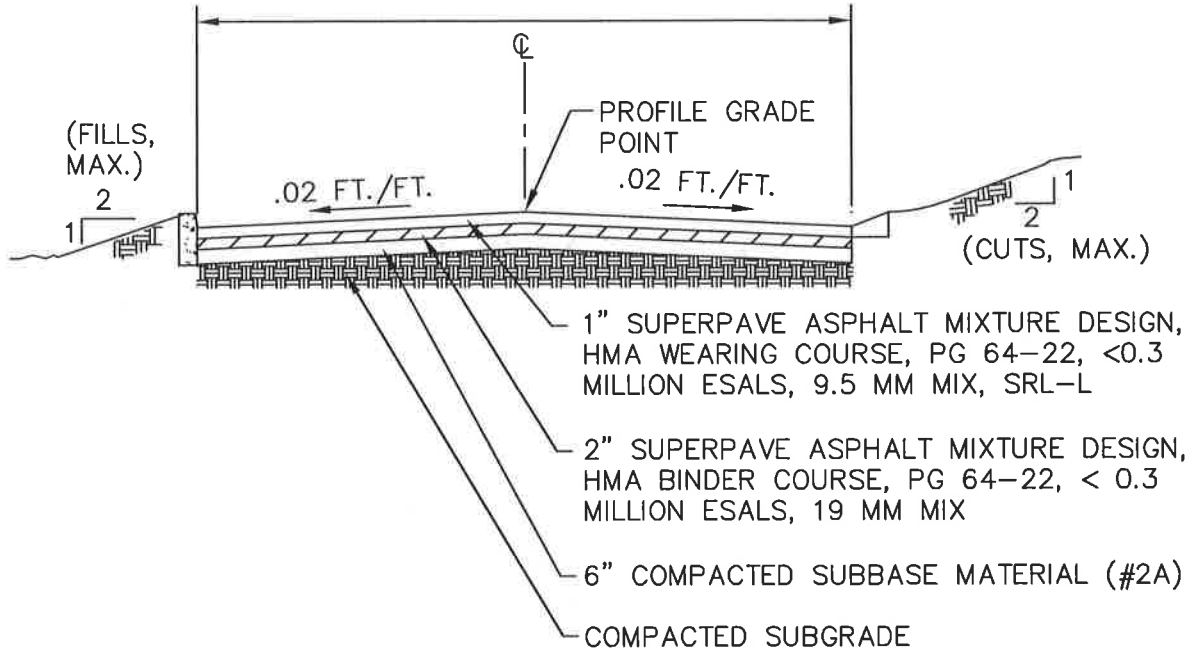

**NOTES:**

1. ROADWAY SHALL INCLUDE A TYPICAL CONCRETE CURB OR TYPICAL BITUMINOUS WEDGE CURB (SEE TYPICAL DETAILS).
2. ALL PAVEMENT/STONE COURSE DIMENSION ARE AFTER COMPACTION.
3. NOT TO SCALE



**TYPICAL COLLECTOR DRIVEWAY**

REVISIONS				DRAWING
NO.	DATE	NO.	DATE	
				<b>SD-013</b>



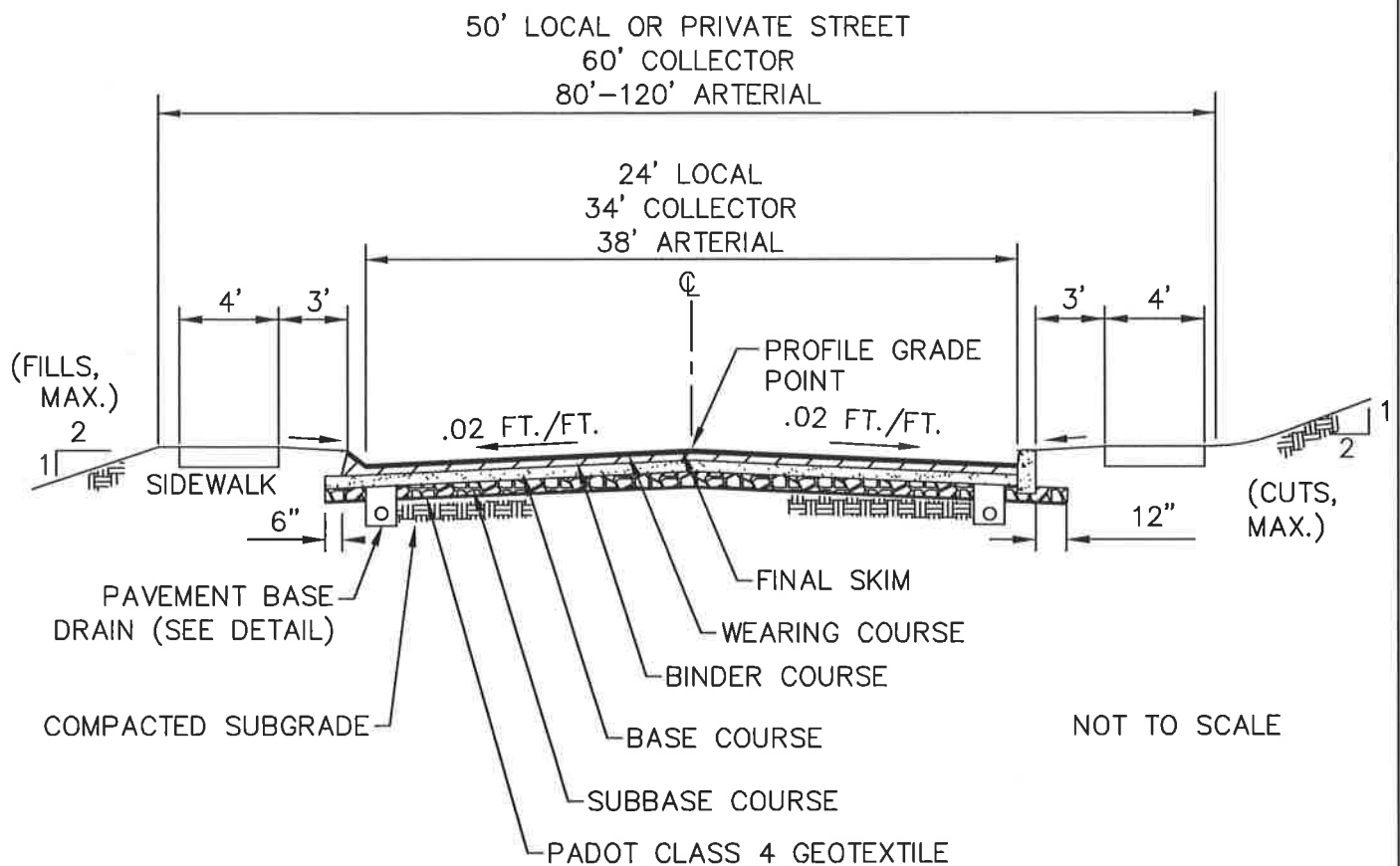

PAVEMENT COURSE		LOCAL OR PRIVATE STREET	COLLECTOR	ARTERIAL
FINAL SKIM	SUPERPAVE ASPHALT MIXTURE DESIGN, HMA WEARING COURSE, PG 64-22, <0.3 MILLION ESALS, 9.5 MM MIX, SRL-L	1"	1"	1"
WEARING COURSE	SUPERPAVE ASPHALT MIXTURE DESIGN, HMA WEARING COURSE, PG 64-22, <0.3 MILLION ESALS, 9.5 MM MIX, SRL-L	1.5"	1.5"	1.5"
BINDER COURSE	SUPERPAVE ASPHALT MIXTURE DESIGN, HMA BINDER COURSE, PG 64-22, < 0.3 MILLION ESALS, 25 MM MIX	3"	5"	6"
BASE COURSE	COMPACTED BASE COURSE MATERIAL (#2A)	2"	2"	2"
SUBBASE COURSE	COMPACTED SUBBASE COURSE MATERIAL (ASHTO #1)	6"	8"	10"



## TYPICAL PUBLIC STREET DETAIL

REVISIONS				DRAWING
NO.	DATE	NO.	DATE	
				<b>SD-014</b>

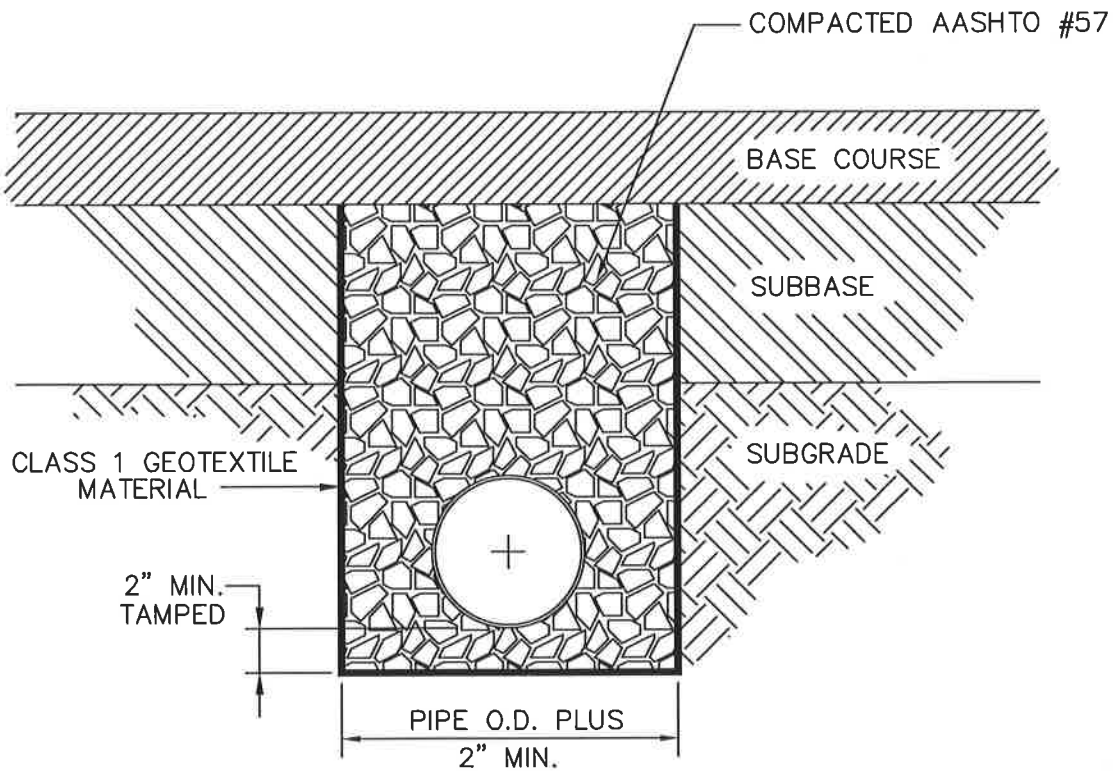

NOT TO SCALE

**NOTES**

1. MATERIALS AND CONSTRUCTION SHALL CONFORM WITH THE REQUIREMENTS OF PENNDOT 408, SECTIONS 610 AND 615.

REFERENCE RC-30-PENNDOT PUBLICATION 72



**SUBSURFACE DRAIN  
(Pavement Base Drain) DETAIL**

REVISIONS				DRAWING
NO.	DATE	NO.	DATE	
				<b>SD-015</b>

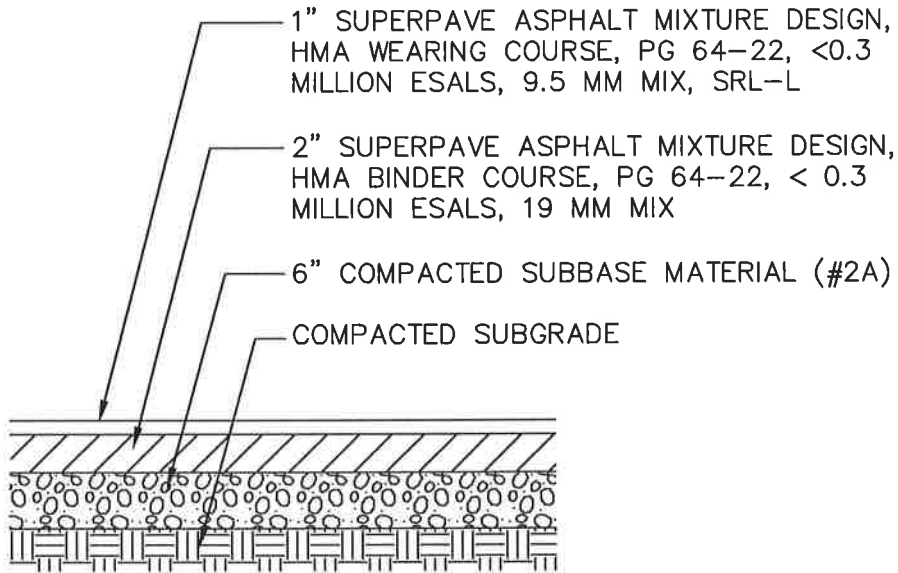

STANDARD DUTY



## TYPICAL PARKING LOT PAVING DETAIL

REVISIONS				DRAWING
NO.	DATE	NO.	DATE	
				<b>SD-016</b>

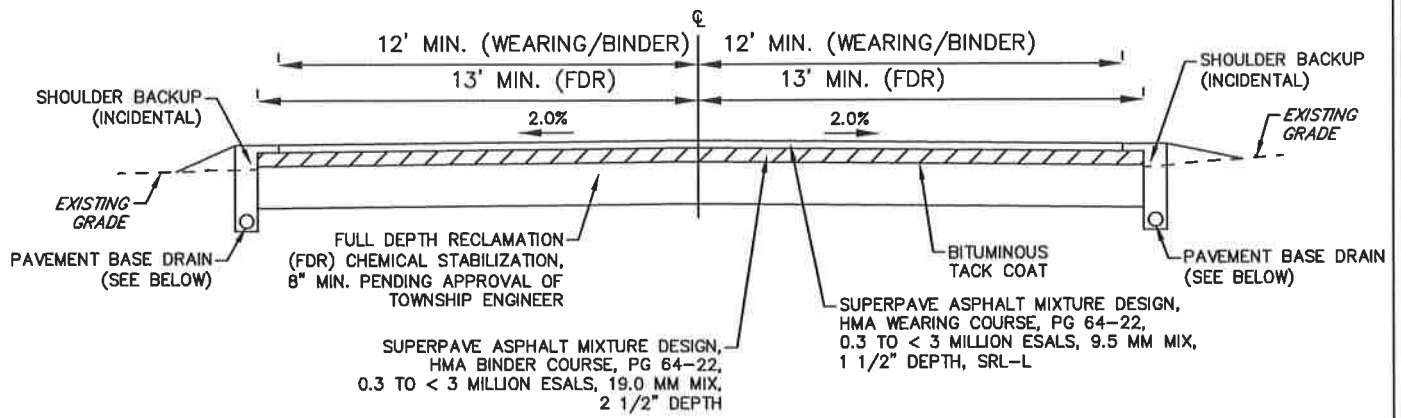

**TYPICAL FULL DEPTH RECLAMATION SECTION**  
NOT TO SCALE

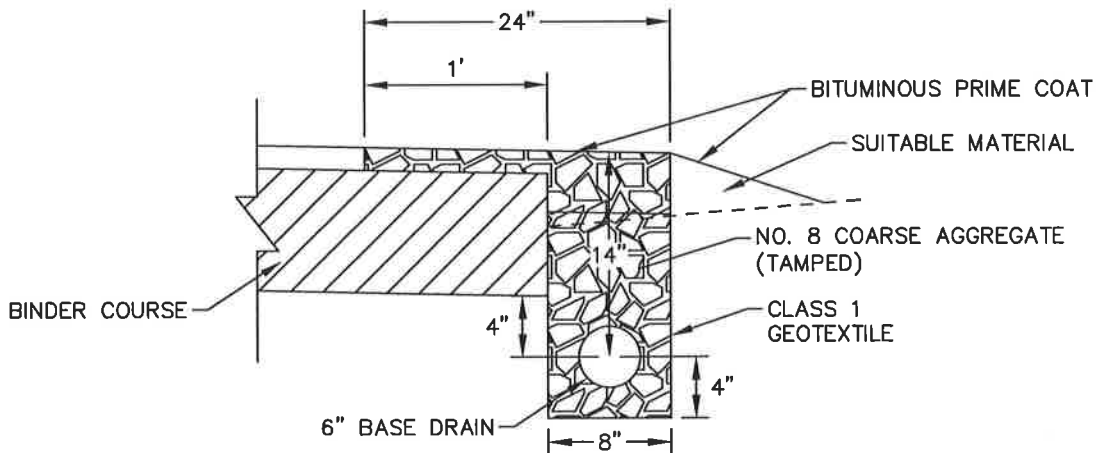

**6" PAVEMENT BASE DRAIN DETAIL**  
**FOR FULL DEPTH RECLAMATION**  
NOT TO SCALE



## TYPICAL FDR FOR RESIDENTIAL ROADS

REVISIONS				DRAWING
NO.	DATE	NO.	DATE	
				<b>SD-017</b>

RESTRICTED USE – SNOW REMOVAL EASEMENT 10' x 20'

# TYPICAL

NOT TO SCALE

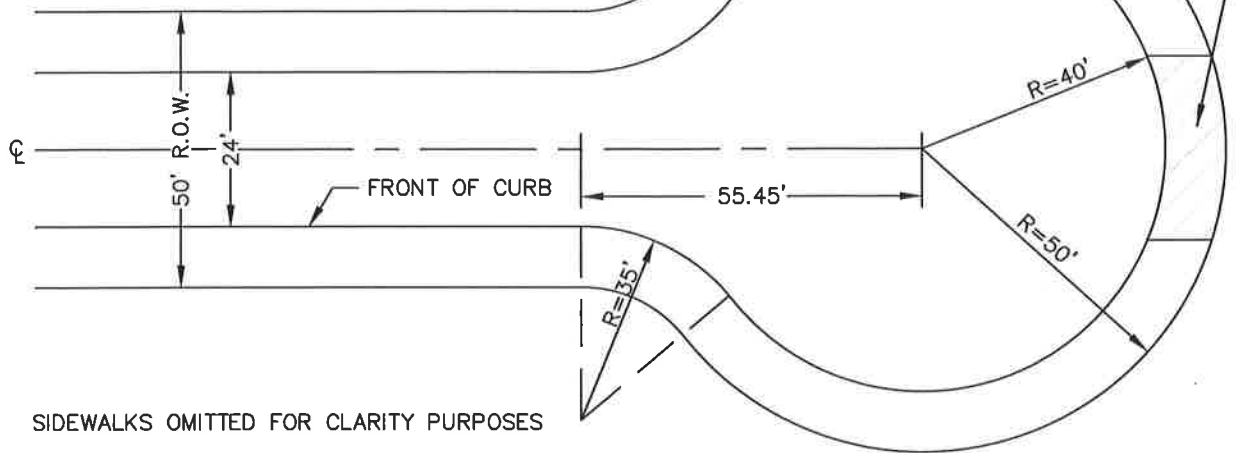

SIDEWALKS OMITTED FOR CLARITY PURPOSES

# OFFSET

NOT TO SCALE

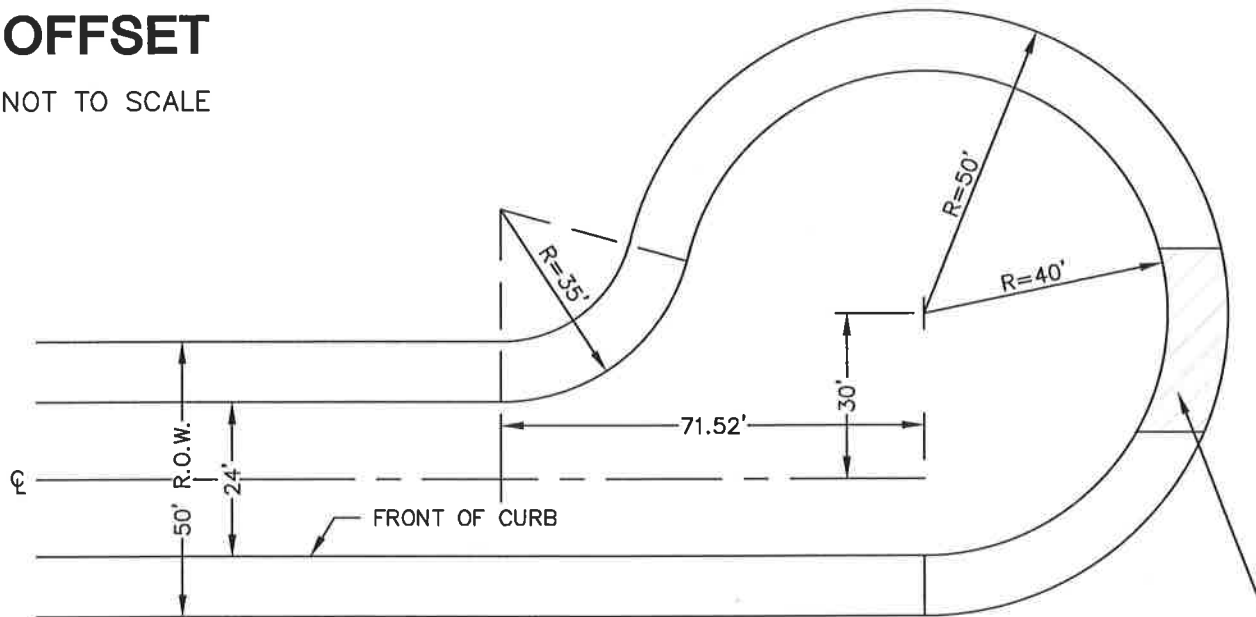

SIDEWALKS OMITTED FOR CLARITY PURPOSES

RESTRICTED USE – SNOW REMOVAL EASEMENT 10' x 20'



## TYPICAL AND OFFSET CUL-DE-SAC DETAILS

REVISIONS				DRAWING
NO.	DATE	NO.	DATE	

**SD-018**

# TYPICAL TEMPORARY CUL-DE-SAC

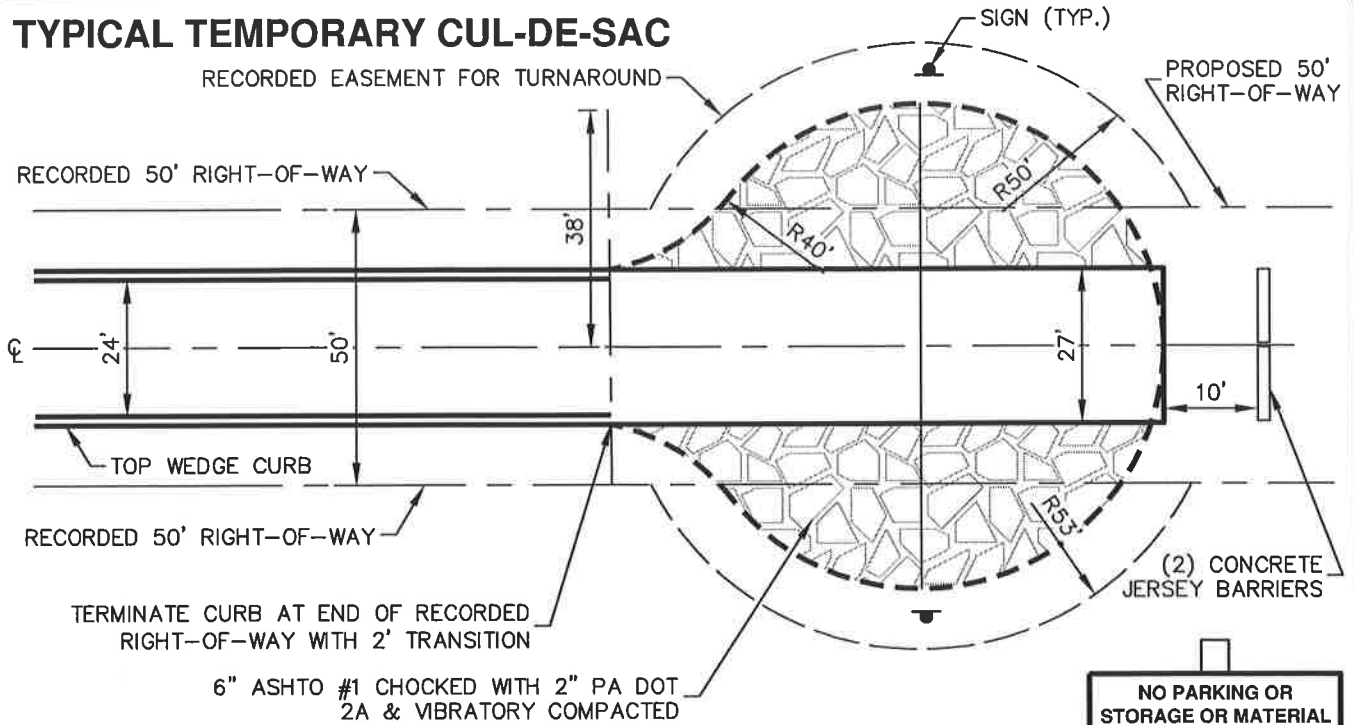

# OFFSET TEMPORARY CUL-DE-SAC

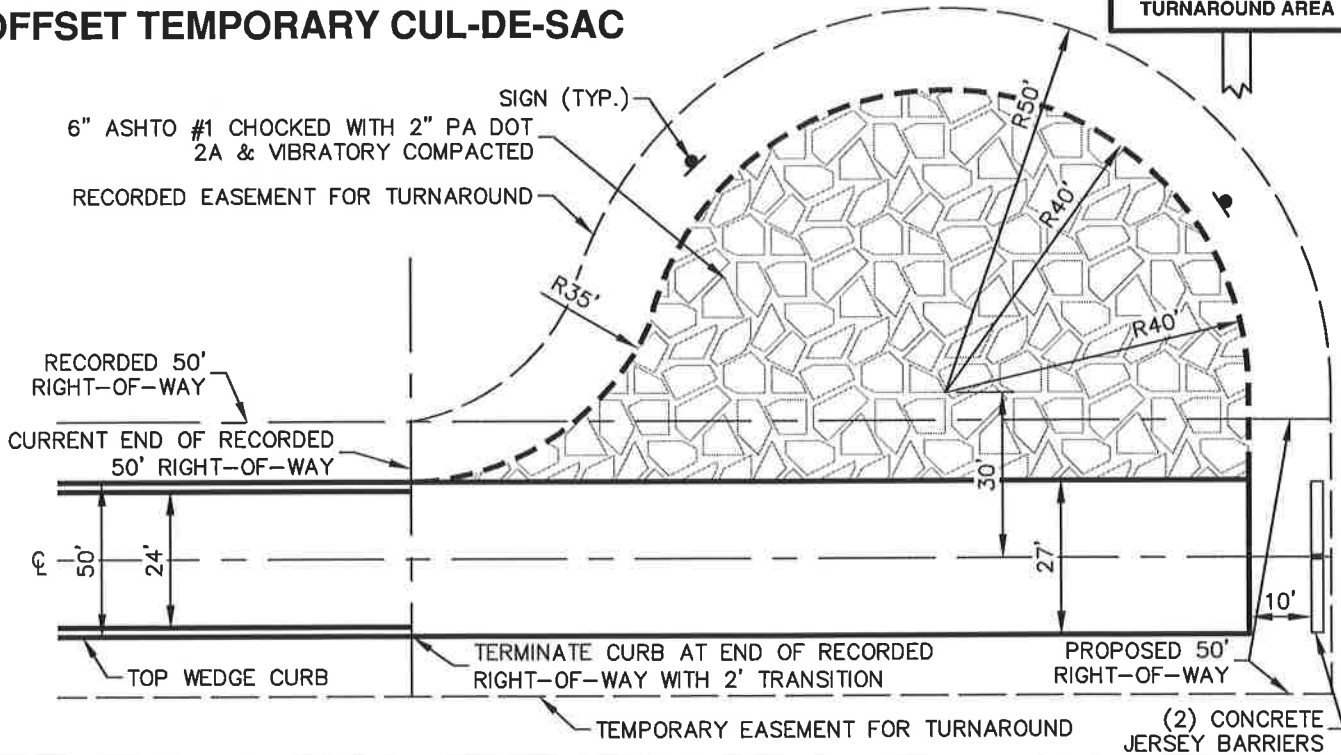

## TEMPORARY CUL-DE-SAC DETAILS

REVISIONS				DRAWING
NO.	DATE	NO.	DATE	
				<b>SD-019</b>

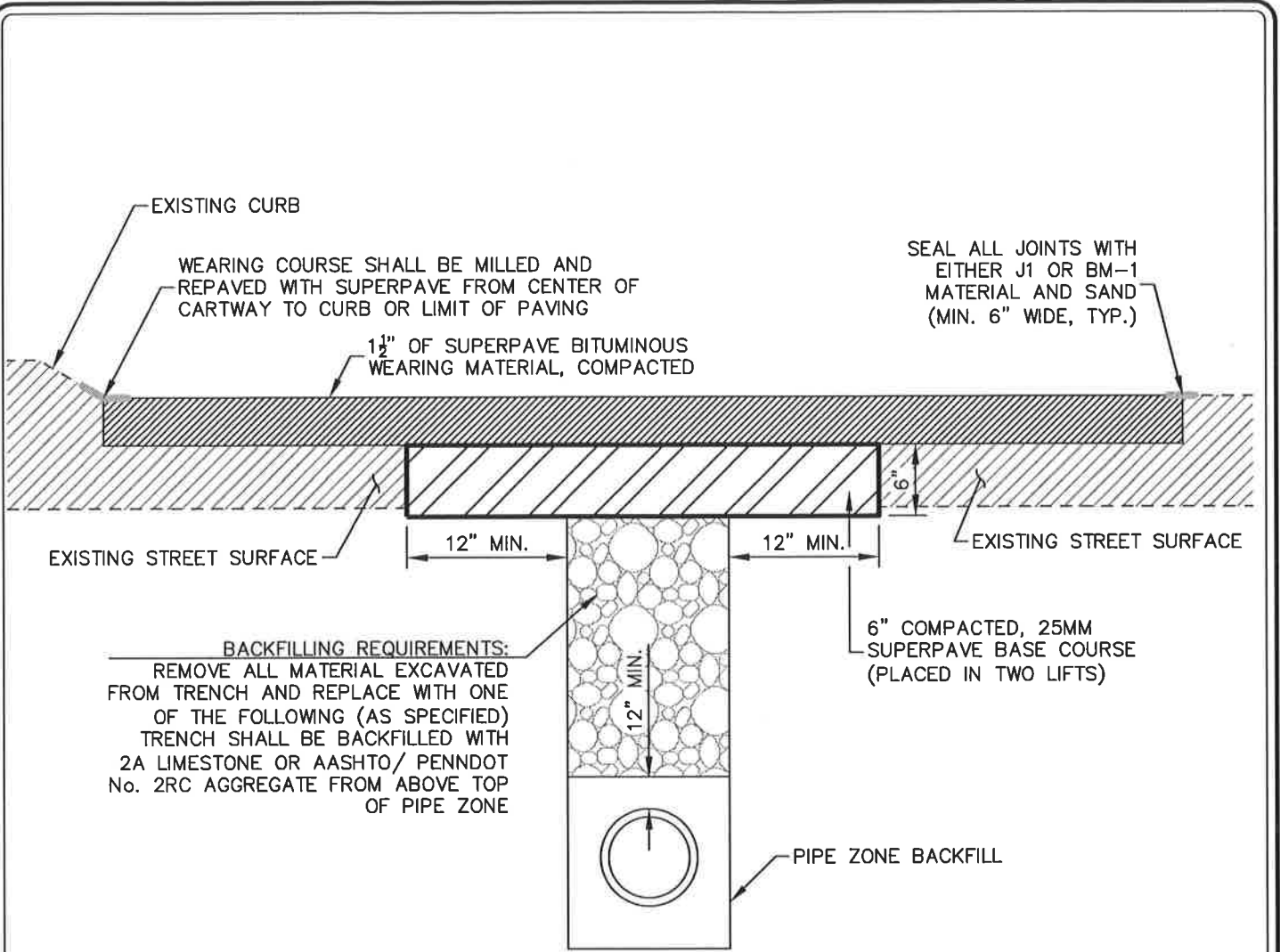

**NOTES:**  
 DURING COLD WEATHER WHEN SUPERPAVE MATERIAL IS NOT AVAILABLE FROM THE ASPHALT PLANTS THE TRENCH SHALL BE BACKFILLED WITH BEDDING MATERIAL TO AN ELEVATION WITHIN 3" OF THE ROAD SURFACE. THE TRENCH SHALL THEN BE SURFACED WITH A TEMPORARY PATCH OF COLD LATCH MATERIAL. AS SOON AS THE ASPHALT PLANTS OPEN IN THE SPRING, THE CONTRACTOR SHALL REMOVE THE COLD PATCH MATERIAL AND SAW-CUT THE REQUIRED BENCHES AND THE SUPERPAVE MATERIAL SHALL THEN BE PAVED AND SEALED. THE CONTRACTOR SHALL BE RESPONSIBLE FOR MAINTENANCE ON THE TEMPORARY PATCH AND SHALL KEEP A SMOOTH RIDING SURFACE ON THE STREET.

PATCH SHALL BE CUT BACK A MINIMUM OF 12" FROM EACH EDGE OF THE TRENCH TO PROVIDE A FIRM BENCH FOR THE EDGES OF THE PATH.

REFERENCE SUPERPAVE PER PA DOT SECTION 408, MIXTURE & DESIGN STANDARDS.



## TYPICAL DETAIL FOR REPAIR OF PAVED STREET

REVISIONS				DRAWING
NO.	DATE	NO.	DATE	
				<b>SD-020</b>

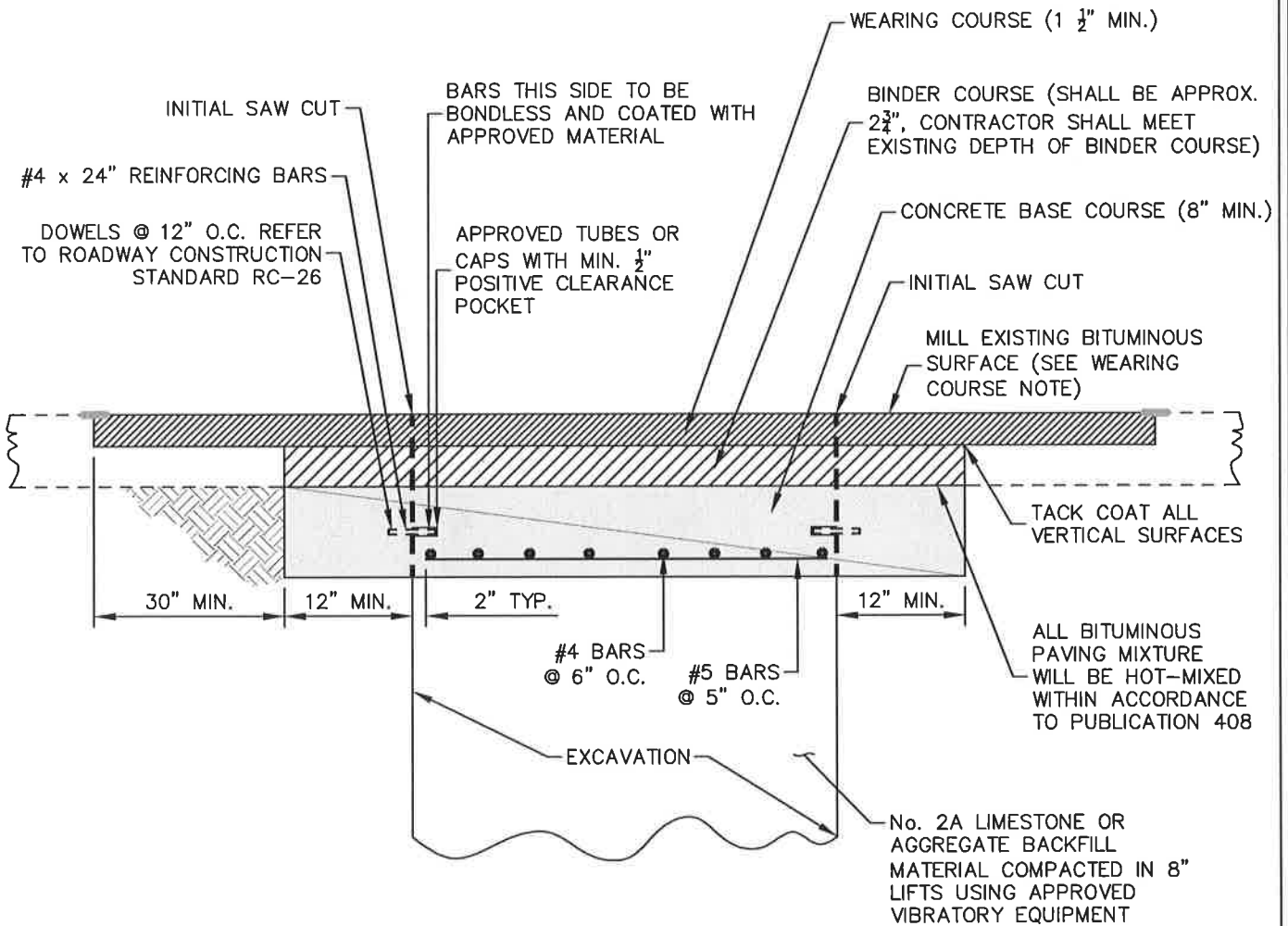

## TYPICAL DETAIL FOR REPAIR OF STREET WITH CONCRETE BASE

REVISIONS				DRAWING
NO.	DATE	NO.	DATE	
				<b>SD-021</b>



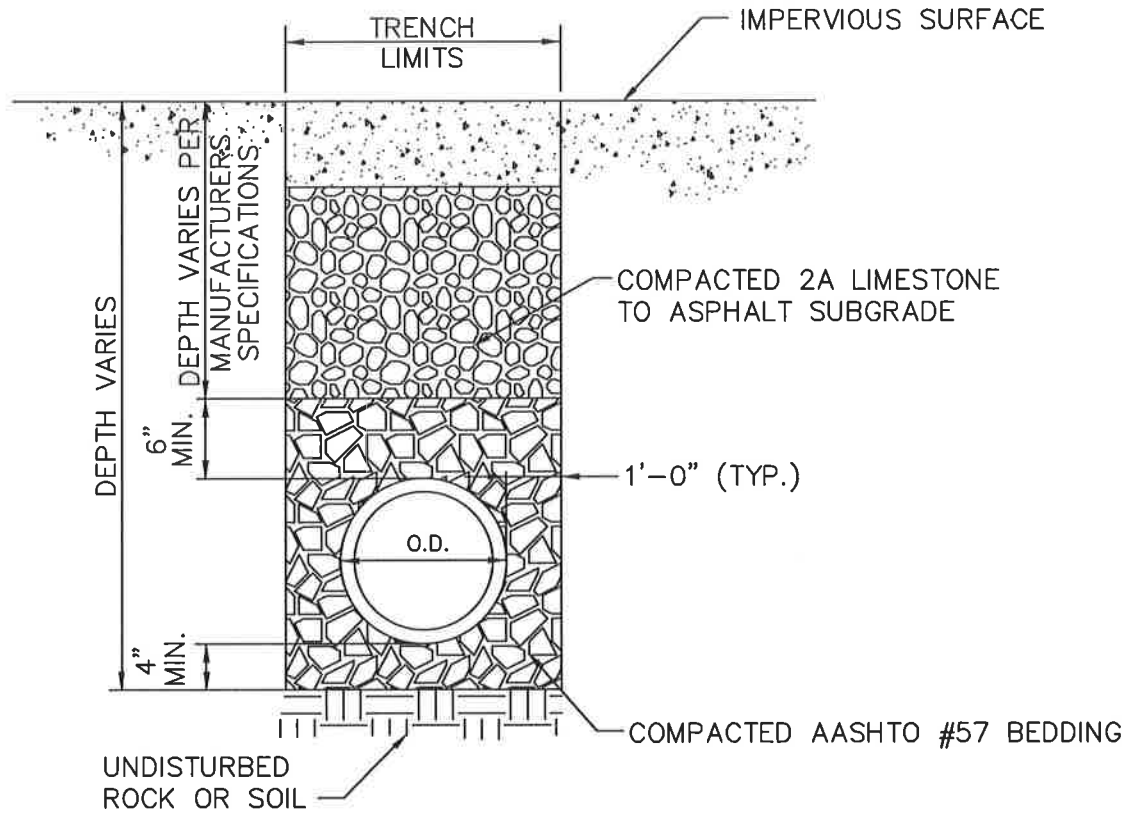

NOT TO SCALE

NOTES:

1. AGGREGATE MATERIAL SHALL BE PLACED IN LAYERS NOT TO EXCEED EIGHT INCHES AND COMPACTED TO THE FOLLOWING MINIMUM REQUIREMENTS. WITHIN THE CARTWAY.

MAXIMUM DRY WEIGHT OF  
BACKFILL MATERIAL (AS  
DETERMINED IN ACCORDANCE  
WITH AASHTO T99)

LESS THE 95.0 LB./CU.FT.  
95.0-99.9 LB./CU. FT.  
100.0-109.9 LB./CU. FT.  
110.0 OR MORE

MAXIMUM FIELD COMPACTION  
REQUIREMENT (PERCENT OF  
MAXIMUM DRY WEIGHT)

UNSUITABLE MATERIAL  
100.  
100.  
95%



## TYPICAL STORM SEWER TRENCH DETAIL-IMPERVIOUS AREA

REVISIONS				DRAWING
NO.	DATE	NO.	DATE	
				<b>SD-022</b>

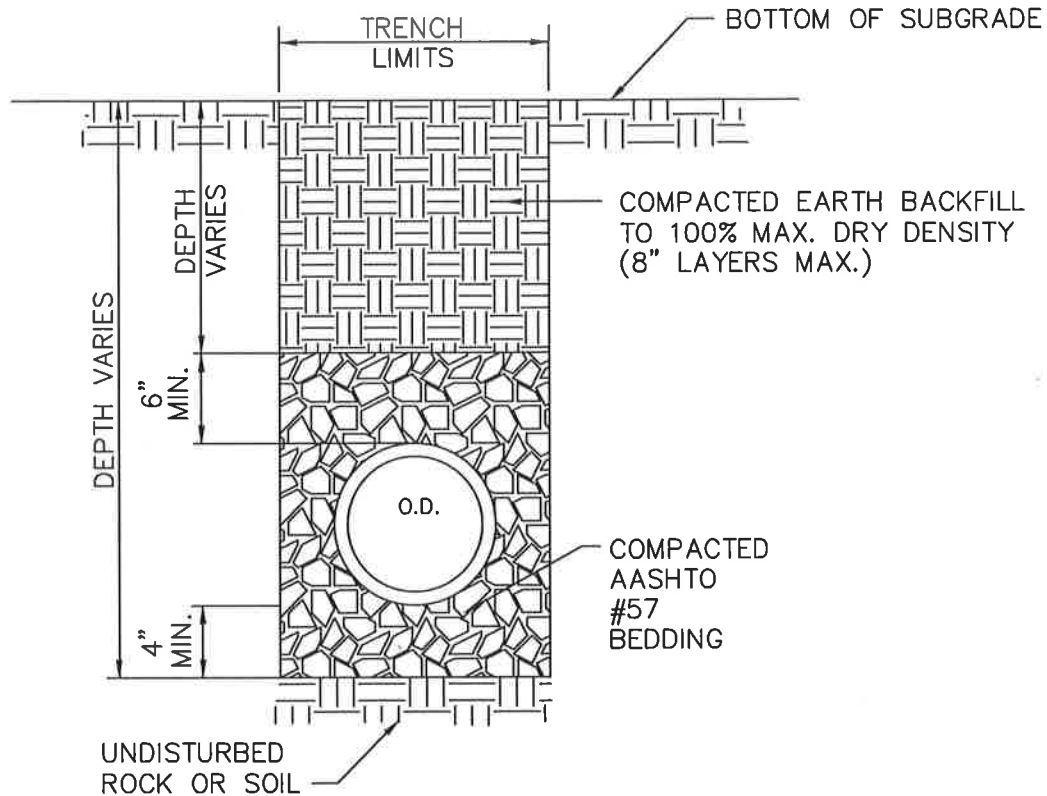

NOT TO SCALE

NOTES:

1. AGGREGATE MATERIAL SHALL BE PLACED IN LAYERS NOT TO EXCEED EIGHT INCHES AND COMPACTED TO THE FOLLOWING MINIMUM REQUIREMENTS. SHOULDER AREAS AS WELL AS BACKFILL WITHIN THE CARTWAY.

MAXIMUM DRY WEIGHT OF BACKFILL MATERIAL (AS DETERMINED IN ACCORDANCE WITH AASHTO T99)

LESS THE 95.0 LB./CU.FT.  
 95.0-99.9 LB./CU. FT.  
 100.0-109.9 LB./CU. FT.  
 110.0 OR MORE

MAXIMUM FIELD COMPACTION REQUIREMENT (PERCENT OF MAXIMUM DRY WEIGHT)

UNSUITABLE MATERIAL  
 100.  
 100.  
 95%

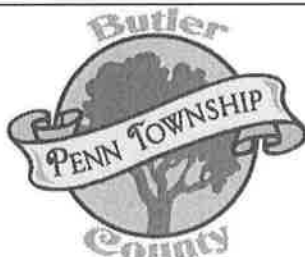

## TYPICAL STORM SEWER TRENCH DETAIL-PERMEABLE AREA

REVISIONS				DRAWING
NO.	DATE	NO.	DATE	
				SD-023

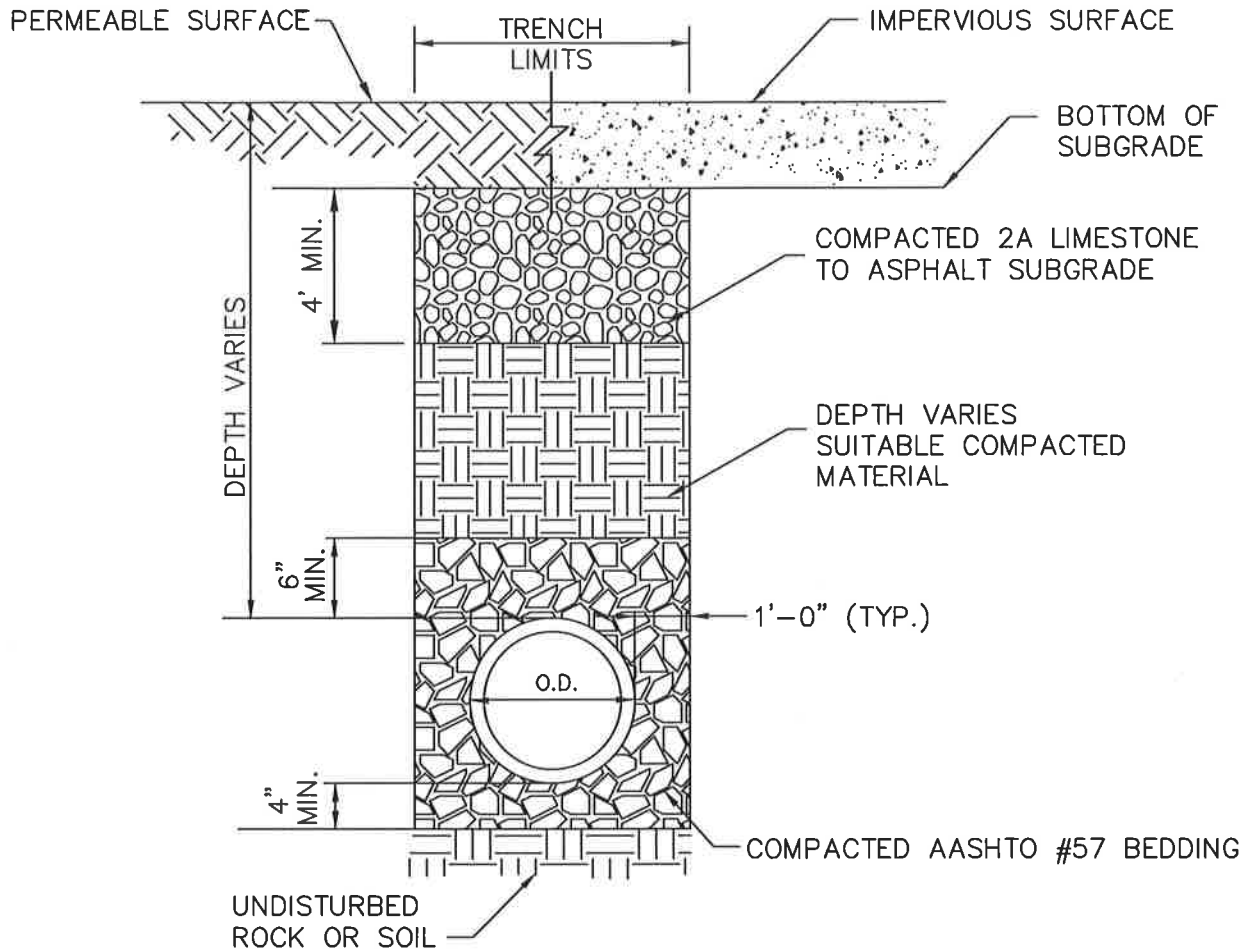

NOT TO SCALE

NOTES:

1. FULL STONE BACKFILL REQUIRED IN ALL TOWNSHIP RIGHT-OF-WAYS.
2. AGGREGATE MATERIAL SHALL BE PLACED IN LAYERS NOT TO EXCEED EIGHT INCHES AND COMPACTED TO THE FOLLOWING MINIMUM REQUIREMENTS. WITHIN THE CARTWAY.

MAXIMUM DRY WEIGHT OF BACKFILL MATERIAL (AS DETERMINED IN ACCORDANCE WITH AASHTO T99)

LESS THE 95.0 LB./CU.FT.  
 95.0-99.9 LB./CU. FT.  
 100.0-109.9 LB./CU. FT.  
 110.0 OR MORE

MAXIMUM FIELD COMPACTION REQUIREMENT (PERCENT OF MAXIMUM DRY WEIGHT)

UNSUITABLE MATERIAL  
 100.  
 100.  
 95%



**TYPICAL STORM SEWER TRENCH  
 DETAIL - DEPTHS EXCEEDING 8 FT**

REVISIONS				DRAWING
NO.	DATE	NO.	DATE	
				<b>SD-024</b>

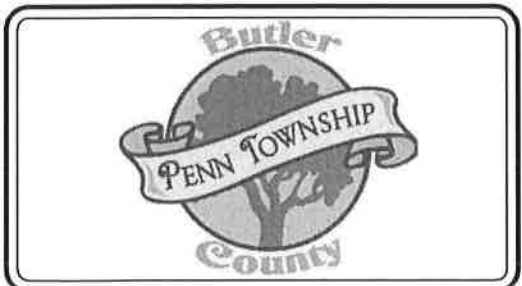
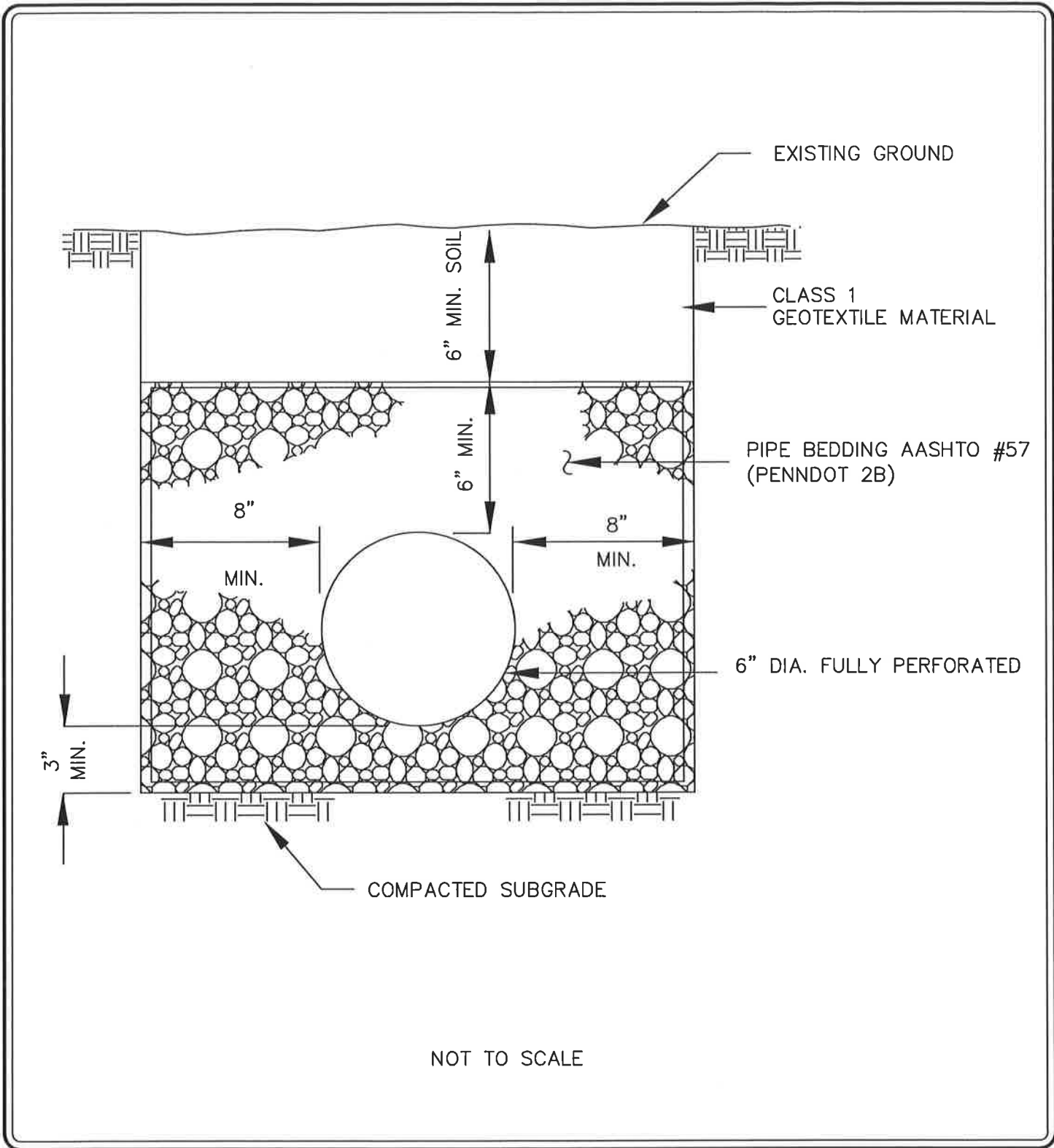

## SUBSURFACE DRAIN DETAIL

REVISIONS				DRAWING
NO.	DATE	NO.	DATE	<b>SD-025</b>

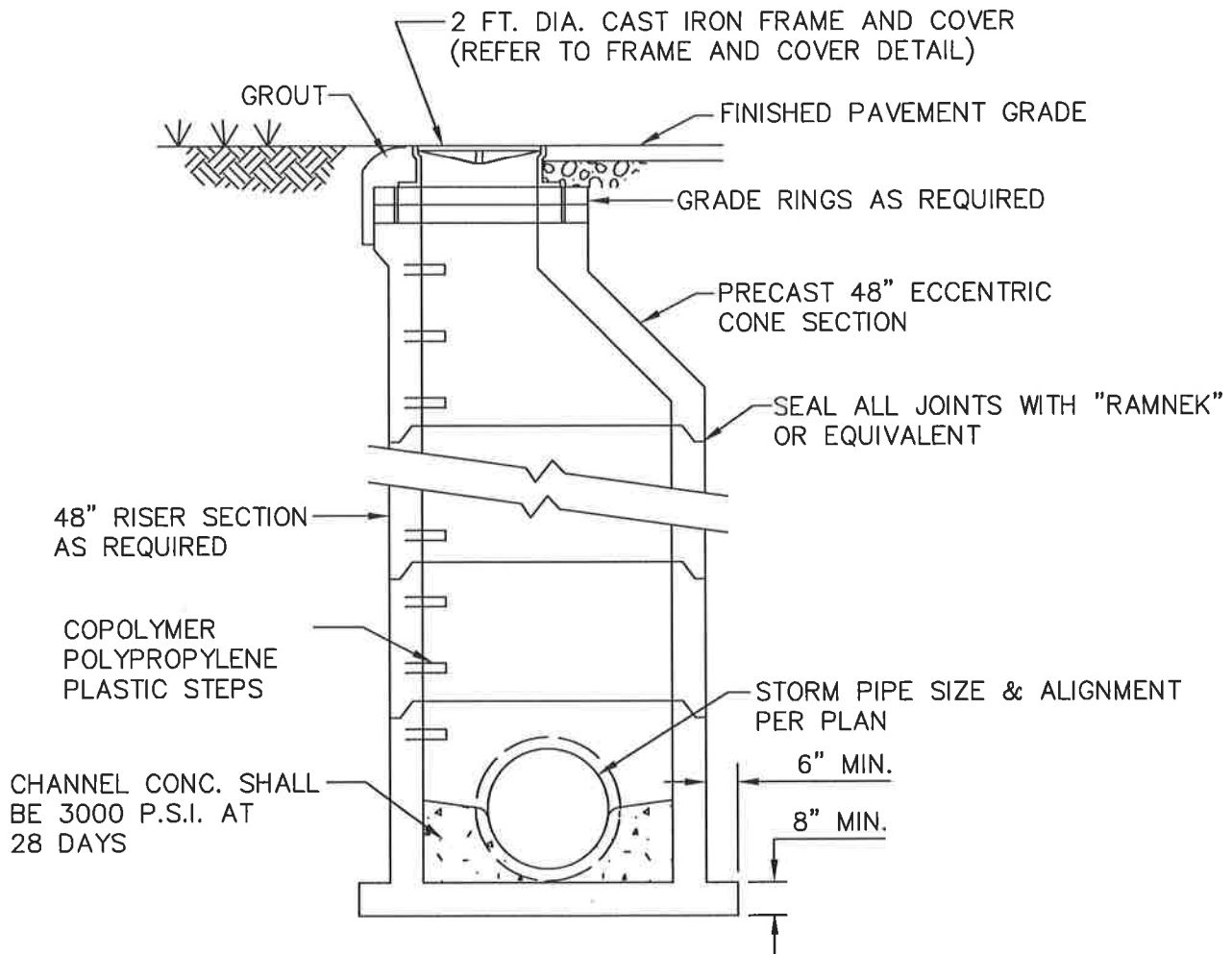

ALL MATERIALS AND CONSTRUCTION SHALL MEET REQUIREMENTS OF PENNDOT PUBLICATION 408  
REFERENCE RC-39 - PENNDOT PUBLICATION 72



## STORM MANHOLE DETAIL (TYPICAL SECTION)

REVISIONS				DRAWING
NO.	DATE	NO.	DATE	
				<b>SD-026</b>

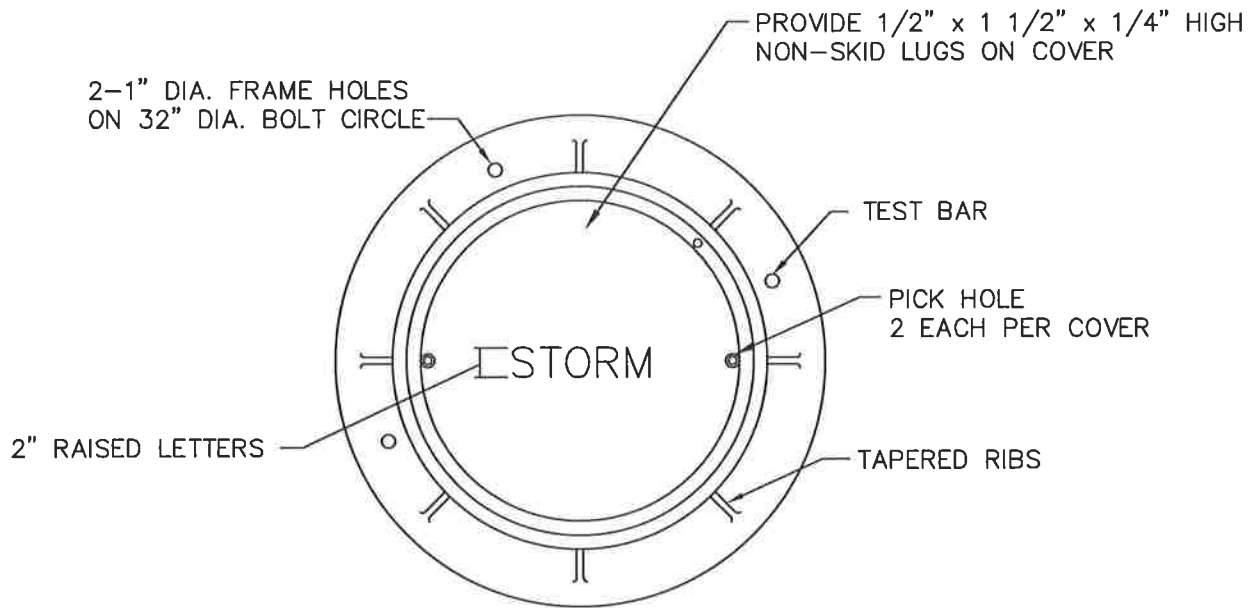

PLAN

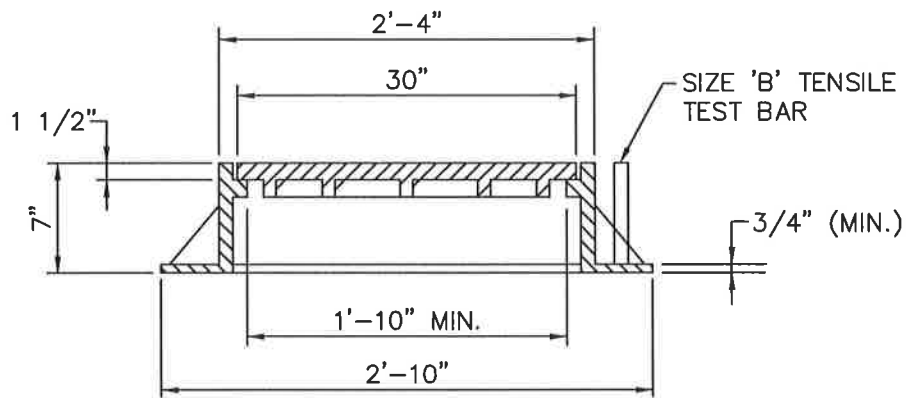

SECTION

NOT TO SCALE

REFERENCE RC-39 - PENNDOT PUBLICATION 72



## STANDARD MANHOLE FRAME & COVER

REVISIONS				DRAWING
NO.	DATE	NO.	DATE	
				SD-027

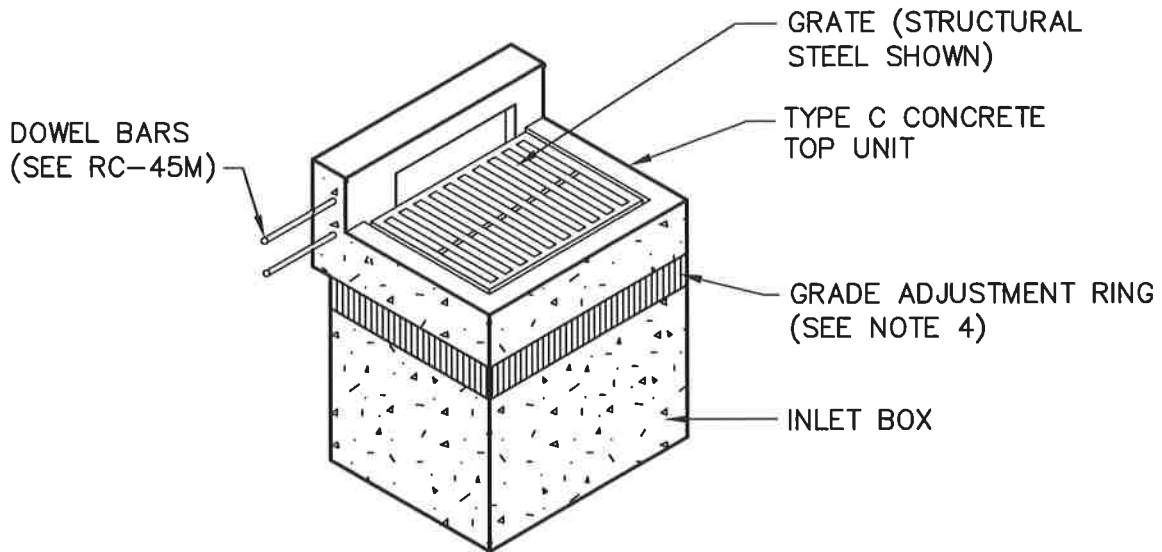

**NOTES:**

1. ALL CONSTRUCTION SHALL BE IN ACCORDANCE WITH PENNDOT PUBLICATION 408, SECTION 605 AND STANDARDS FOR ROADWAY CONSTRUCTION, RC-34. CONTRACTOR SHALL VERIFY INLET BOX SIZING BASED ON PIPE SIZES AND ALIGNMENT PRIOR TO ORDERING PRECAST STRUCTURES.
2. ALL DRAINAGE STRUCTURES SHALL HAVE POURED-IN-PLACE CONCRETE CHANNEL BOTTOMS.
3. NO PIPES SHALL ENTER INLET BOX AT CORNER.
4. PROVIDE GRADE ADJUSTMENT RINGS WHEN REQUIRED. (SEE RC-45M FOR DETAILS)

**TYPE C INLET DETAIL**

NOT TO SCALE



**TYPE C INLET DETAIL**

REVISIONS				DRAWING
NO.	DATE	NO.	DATE	
				<b>SD-028</b>

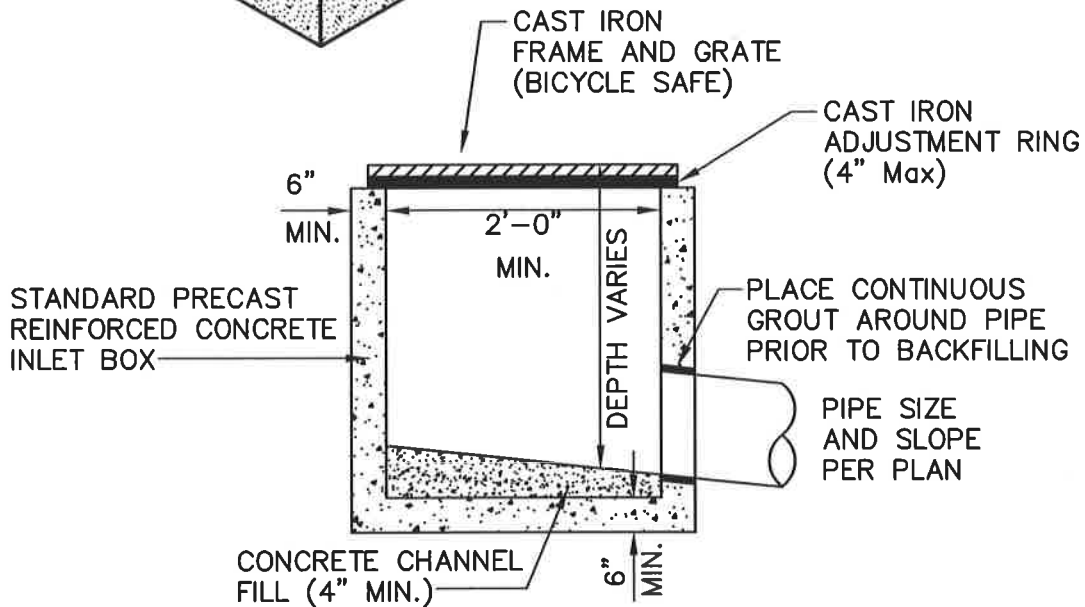
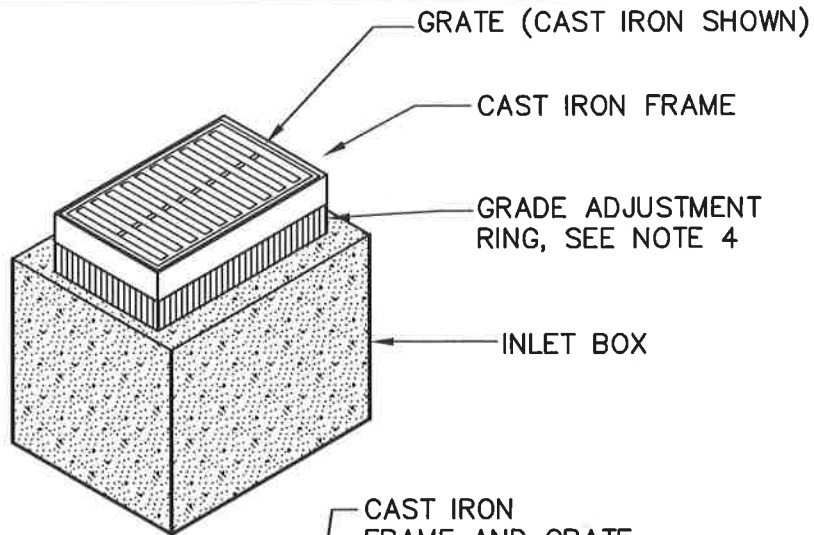

**NOTES:**

1. ALL CONSTRUCTION SHALL BE IN ACCORDANCE WITH PENNDOT PUBLICATION 408, SECTION 605 AND STANDARDS FOR ROADWAY CONSTRUCTION, RC-34. CONTRACTOR SHALL VERIFY INLET BOX SIZING BASED ON PIPE SIZES AND ALIGNMENT PRIOR TO ORDERING PRECAST STRUCTURES.
2. ALL DRAINAGE STRUCTURES SHALL HAVE POURED-IN-PLACE CONCRETE CHANNEL BOTTOMS.
3. NO PIPES SHALL ENTER INLET BOX AT CORNER.
4. PROVIDE GRADE ADJUSTMENT RINGS WHEN REQUIRED. SEE RC-45M FOR DETAILS.
5. PROVIDE ALUMINUM STEPS IN INLETS OVER 5' DEEP.



## TYPICAL INLET DETAIL

REVISIONS				DRAWING
NO.	DATE	NO.	DATE	
				<b>SD-029</b>



PIPE DIA.	L	W	A
15"	4.0'	4.0'	12"
18"	4.0'	4.0'	12"
24"	4.5'	4.25'	12"

**NOTES:**

1. CONCRETE SHALL BE CLASS "A".
2. EXPOSED EDGES SHALL BE CHAMFERED ONE (1) INCH.
3. ADD 1'-0" TO DIMENSION 'L' WHEN ORIFICE PLATE IS TO BE PLACED ON HEADWALL.

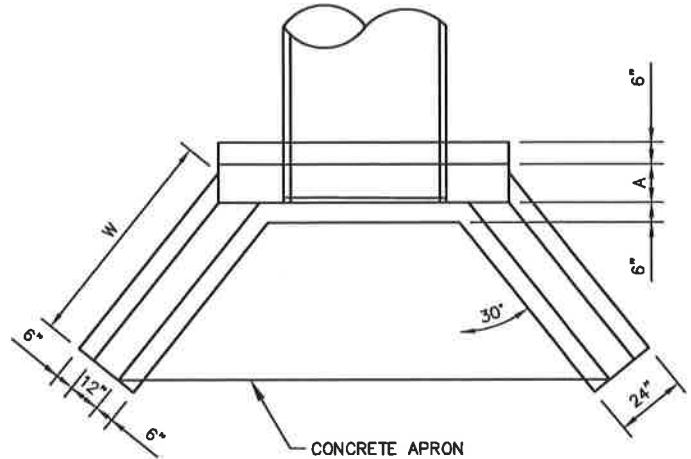

**PLAN**

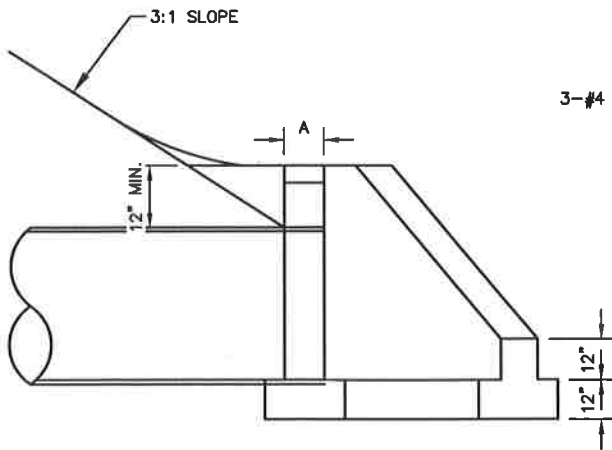

**SIDE ELEVATION**

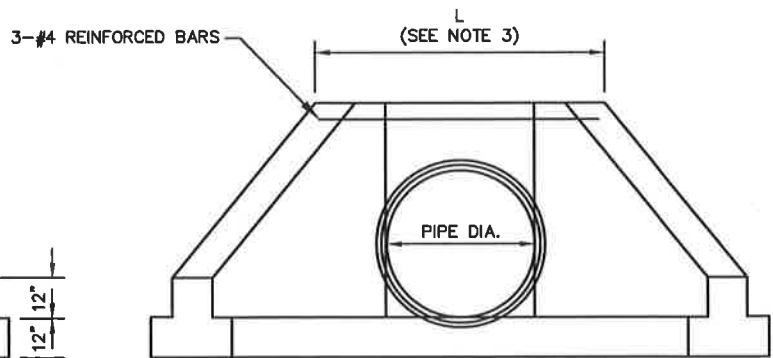

**FRONT ELEVATION**



**TYPICAL CONCRETE END WALL FOR 15" - 24" DIA PIPE**

REVISIONS				DRAWING
NO.	DATE	NO.	DATE	
				<b>SD-030</b>

TABLE A (ENGLISH)

2 : 1 EMBANKMENT SLOPES

PIPE DIAMETER	SKEW $\alpha = 90^\circ$ TO $60^\circ$ $\theta = 30^\circ$			SKEW $\alpha = 55^\circ$ $\theta = 35^\circ$			SKEW $\alpha = 50^\circ$ $\theta = 40^\circ$			SKEW $\alpha = 45^\circ$ $\theta = 45^\circ$			SKEW $\alpha = 40^\circ$ $\theta = 50^\circ$			SKEW $\alpha = 30^\circ$ $\theta = 60^\circ$			SKEW $\alpha = 20^\circ$ $\theta = 70^\circ$			SKEW $\alpha = 10^\circ$ $\theta = 80^\circ$				
	$D_{D-W}$ (IN.)	$L_{D-W}$ (FT.)	$W$ (FT.)	$L_{D-W}$ (FT.)	$W$ (FT.)	$W_2$ (FT.)	$L_{D-W}$ (FT.)	$W$ (FT.)	$W_2$ (FT.)	$L_{D-W}$ (FT.)	$W$ (FT.)	$W_2$ (FT.)	$L_{D-W}$ (FT.)	$W$ (FT.)	$W_2$ (FT.)	$L_{D-W}$ (FT.)	$W$ (FT.)	$W_2$ (FT.)	$L_{D-W}$ (FT.)	$W$ (FT.)	$W_2$ (FT.)	$L_{D-W}$ (FT.)	$W$ (FT.)	$W_2$ (FT.)		
36	5.8	0	4.6	6.0	0.33	4.9	6.2	0.5	5.2	6.5	0.67	5.7	7.0	0.75	6.2	8.3	1.33	8.0	11.1	1.75	11.7	19.6	5.0	23.0	4.6	12
42	6.3	0	5.8	6.6	0.33	6.1	6.9	0.5	6.5	7.3	0.67	7.1	7.8	0.75	7.8	9.3	1.33	10.0	12.5	1.75	14.6	22.5	5.0	28.8	5.8	12
48	6.9	0	6.9	7.2	0.33	7.3	7.5	0.5	7.8	8.0	0.67	8.5	8.5	0.75	9.4	10.3	1.33	12.0	14.0	1.75	17.5	25.3	5.0	34.6	6.9	12
54	7.5	0	8.0	7.8	0.33	8.5	8.2	0.5	9.1	8.7	0.67	9.9	9.3	0.75	10.9	11.3	1.33	14.0	15.5	1.75	20.5	28.2	5.0	40.3	8.0	12
60	8.1	0	9.2	8.4	0.33	9.8	8.8	0.5	10.4	9.4	0.67	11.3	10.1	0.75	12.5	12.3	1.33	16.0	16.9	1.75	23.4	31.1	5.0	46.0	9.2	15
72	9.2	0	11.5	9.6	0.33	12.2	10.1	0.5	13.0	10.8	0.67	14.1	11.7	0.75	15.6	14.3	1.33	20.0	19.8	1.75	29.2	36.9	5.0	57.6	11.5	15

\*\*  $SD = \frac{D_{D-W}}{\cos \theta} = \frac{D_{D-W}}{\sin \text{SKEW } \alpha}$   
 $L_{D-W} = SD + 2.3'$

$W = \frac{20_{D-W} - 2.0'}{\cos \theta}$  FOR 2:1 SLOPE

$W = \frac{X}{\cos \theta} (0_{D-W} \theta .5 - \frac{1.0}{X})$  (FOR VARIABLE SLOPE WHEN X EQUALS HORIZONTAL DIMENSION OF THE SLOPE DESIGNATION.)

NOTE:  
REINFORCING STEEL SHALL BE REQUIRED THROUGH SHOP DRAWING SUBMITTAL. SEE PA DOT 408 SPECIFICATION.

RIP-RAP OR SOME FORM OF ENERGY DISSIPATION WILL BE REQUIRED AT TERMINATION OF DEVICE. REFER TO PA DEP EROSION AND SEDIMENTATION AND/OR SWM BMP MANUALS.

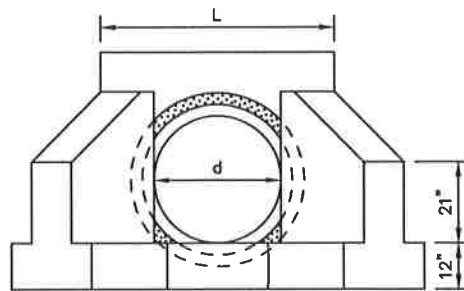
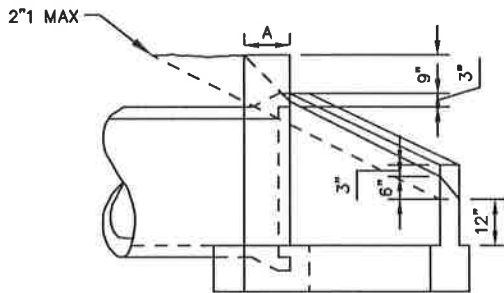
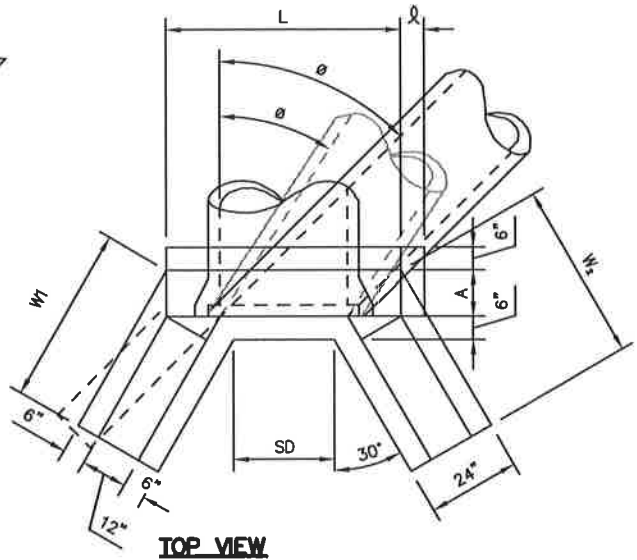
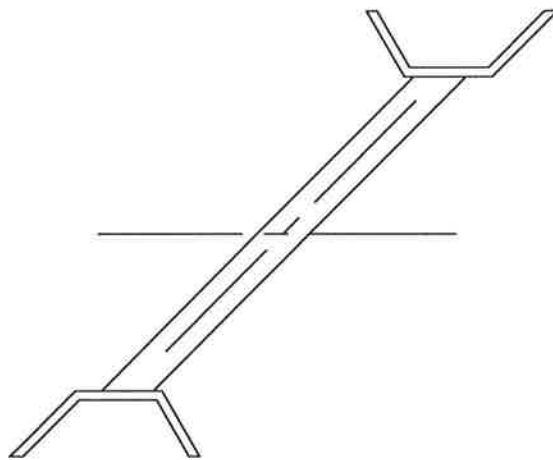

SIDE VIEW

END VIEW



TYPICAL CONCRETE END WALL FOR 36" - 72" DIA PIPE

REVISIONS				DRAWING
NO.	DATE	NO.	DATE	
				SD-031

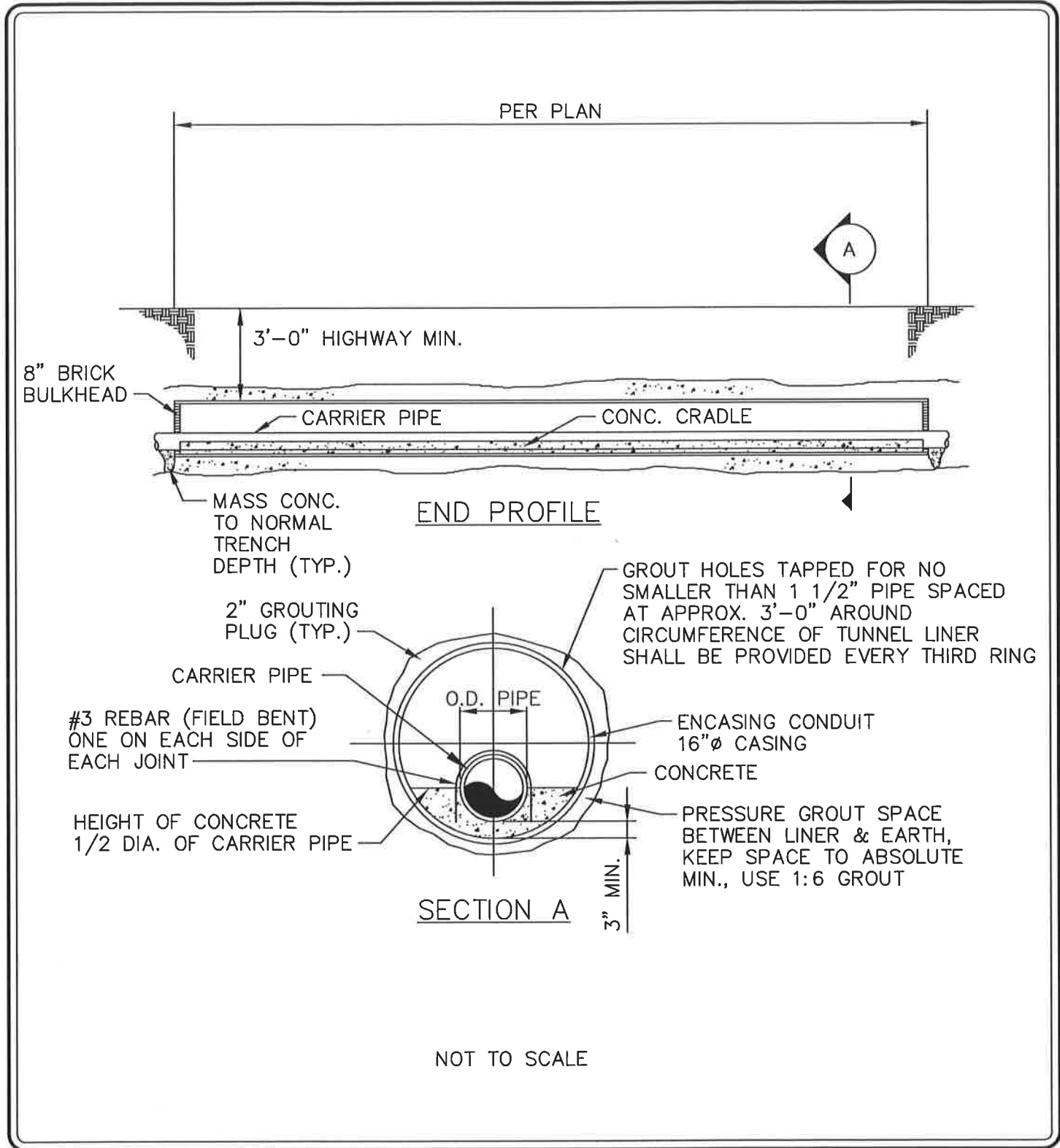

## TUNNEL INSTALLATION DETAIL

REVISIONS				DRAWING
NO.	DATE	NO.	DATE	
				<b>SD-032</b>

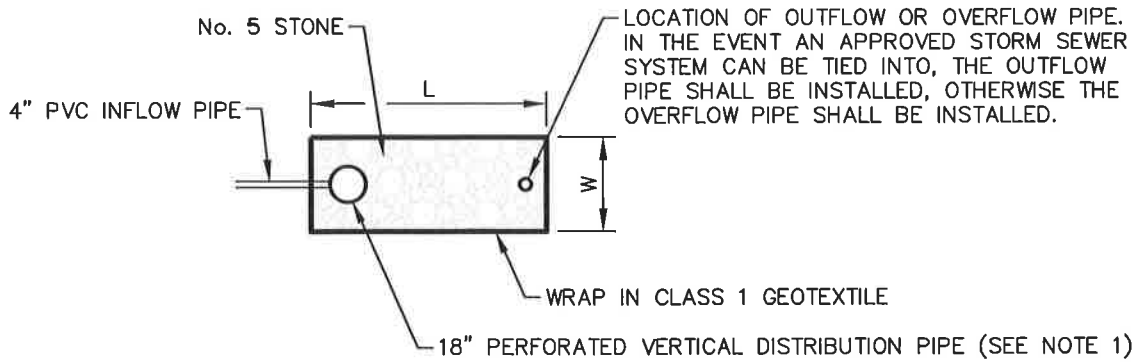

**PLAN VIEW**

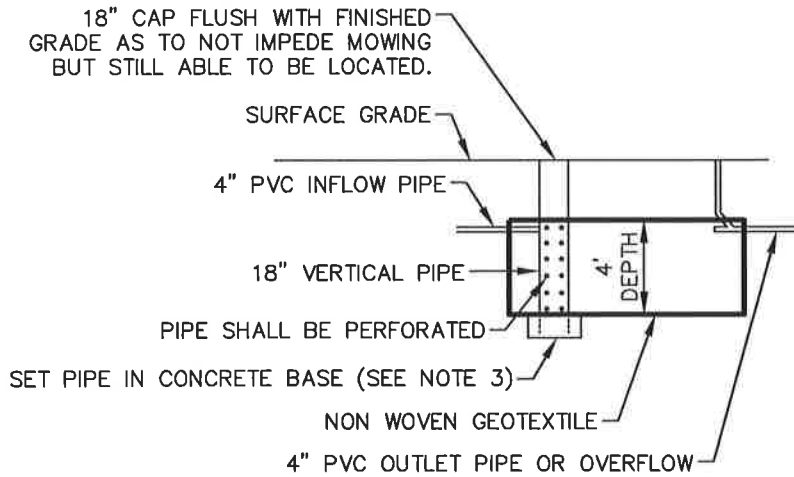

**SECTION**

**NOTES:**

1. A MINIMUM OF 6 ( $\frac{1}{2}$ " $\phi$ ) PERFORATIONS PER 6-INCHES OF PIPE EQUALLY SPACED IN AN OVERALL STAGGERED CONFIGURATION.
2. THE SIZE OF THE CONCRETE BASE SHALL BE LARGE ENOUGH TO PROVIDE A MINIMUM 1.0 FACTOR OF SAFETY FOR UPLIFT FORCES.
3. SUMPS IN FILL AREAS ARE NOT PERMITTED.
4. ANY METAL MATERIALS IN THE SUMP SHALL BE GALVANIZED.
5. SUMP SHALL BE WRAPPED IN A NON WOVEN GEOTEXTILE.

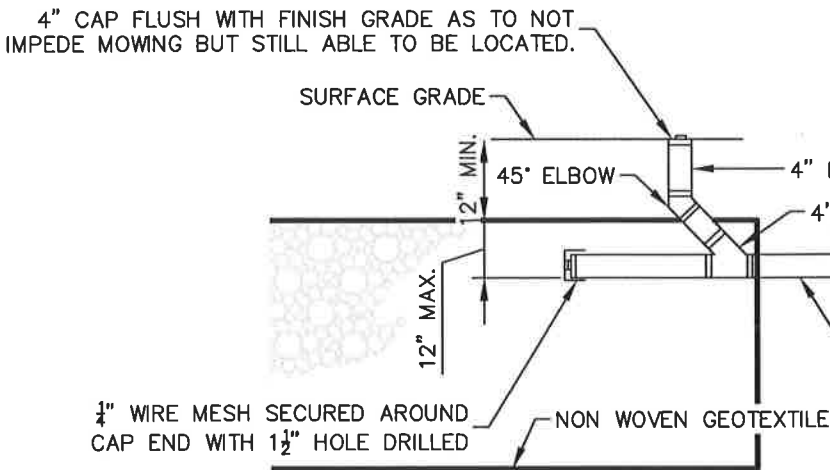

**OUTFLOW PIPE DETAILS**



**ROCK SUMP**

REVISIONS				DRAWING
NO.	DATE	NO.	DATE	
				<b>SD-033</b>

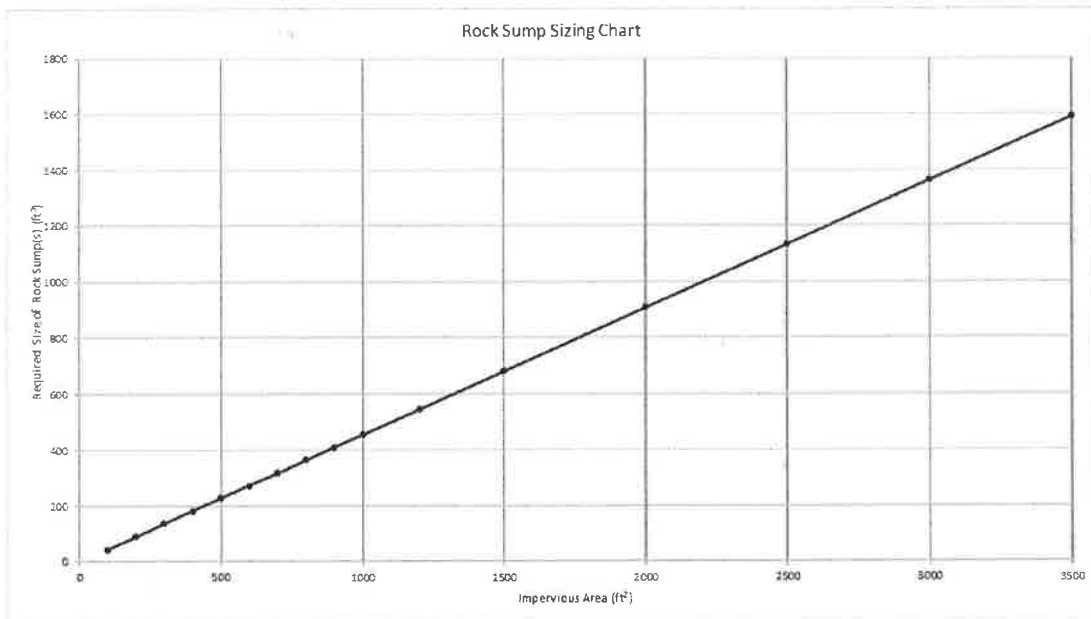

Impervious Area (ft <sup>2</sup> )	Runoff Volume (ft <sup>3</sup> )	Required Size of the Rock Sump (ft <sup>3</sup> )
100	18	45
200	36	91
300	55	136
400	73	182
500	91	227
600	109	273
700	127	318
800	145	364
900	164	409
1000	182	454
1200	218	545
1500	273	682
2000	364	909
2500	454	1136
3000	545	1363
3500	636	1591

**NOTES:**

1. THE TOTAL REQUIRED STORAGE VOLUME SHOULD BE DIVIDED BY MULTIPLE SUMP LOCATIONS.
2. BASED UPON A 2-YEAR, 2.41 INCH RAINFALL EVENT.
3. SUMP TO BE FILLED WITH CLEAN WASHED, UNIFORMLY GRATED AGGREGATE WITH 40% VOID CAPACITY. (AASHTO No. 3 OR APPROVED EQUAL)



## ROCK SUMP STORAGE CHART

REVISIONS				DRAWING
NO.	DATE	NO.	DATE	
				<b>SD-034</b>

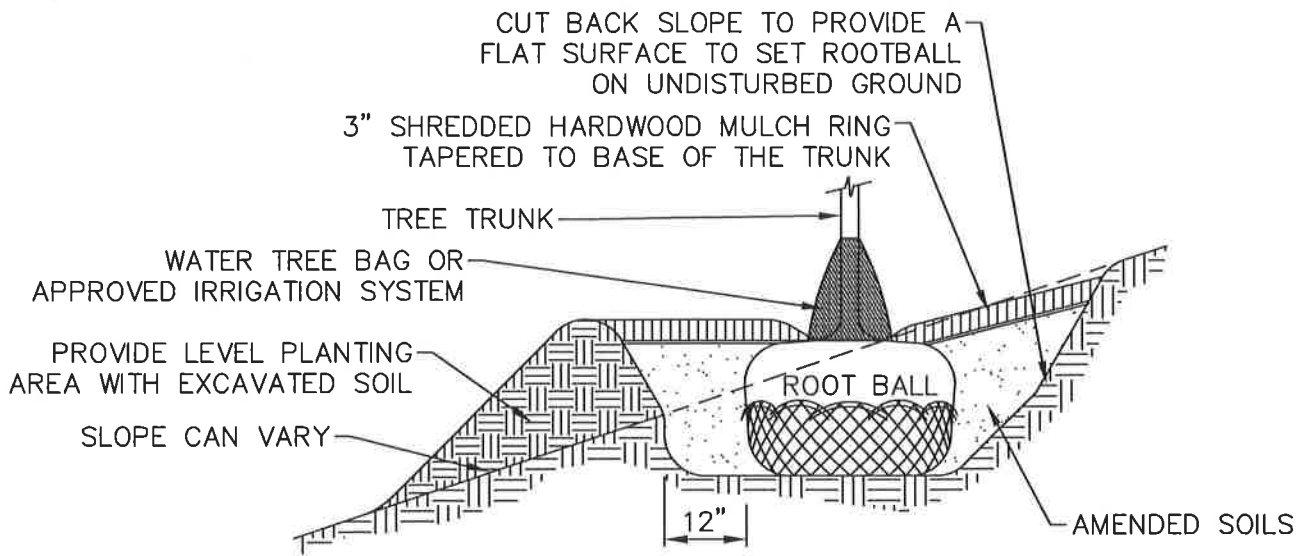

NOT TO SCALE

**NOTE:**

1. CONTRACTOR IS TO SUBMIT A MAINTENANCE PLAN FOR TOWNSHIP APPROVAL. MAINTENANCE PLAN SHOULD INCLUDE A WATERING SCHEDULE FOR A MINIMUM DURATION OF ONE YEAR POST INSTALLATION.
2. ALL VEGETATION SHALL BE PLACED 30 FEET ON CENTER AND STAGGERED BY ROWS.
3. ALL DECIDUOUS VEGETATION SHALL BE A MIN. 1 INCH CALIBER DBH. ALL EVERGREEN VEGETATION SHALL BE A MIN. HEIGHT OF 6 FEET.
4. A VARIETY OF PLANT MATERIAL SHALL BE PROVIDED. A SINGLE SPECIES SHALL NOT EXCEED A MAXIMUM OF 33% OF THE TOTAL PROPOSED VEGETATION.
5. THE CHART BELOW LISTS RECOMMENDED SPECIES. ANY ALTERNATIVE SPECIES SHALL BE APPROVED BY THE TOWNSHIP.

**RECOMMENDED SPECIES**

BOTANICAL NAME	COMMON NAME	PLANTING SIZE	MINIMUM SPACING
JUNIPERUS VIRGINIANA	EASTERN RED CEDAR	MIN 6' HT.	30' O.C.
ROBINIA PSEUDOACACIA	BLACK LOCUST	MIN 1" CAL.	30' O.C.
RHUS AROMATICA	FRAGRANT SUMAC	MIN 1" CAL.	30' O.C.
RHUS GLABRA	SMOOTH SUMAC	MIN 1" CAL.	30' O.C.
PRUNUS SEROTINA	BLACK CHERRY	MIN 1" CAL.	30' O.C.
CATALPA SPECIOSA	NORTHERN CATALPA	MIN 1" CAL.	30' O.C.
LIRIODENDRON TULIPIFERA	TULIPTREE	MIN 1" CAL.	30' O.C.
PINUS RIGIDA	PITCH PINE	MIN 6' HT.	30' O.C.
PINUS STROBUS	EASTERN WHITE PINE	MIN 6' HT.	30' O.C.
POPULUS GRADIDENTATA	BIG-TOOTH ASPEN	MIN 1" CAL.	30' O.C.
QUERUS ALBA	WHITE OAK	MIN 1" CAL.	30' O.C.
CELTIS OCCIDENTALIS	COMMON HACKBERRY	MIN 1" CAL.	30' O.C.



**REFORESTATION DETAIL**

REVISIONS				DRAWING
NO.	DATE	NO.	DATE	
				<b>SD-035</b>

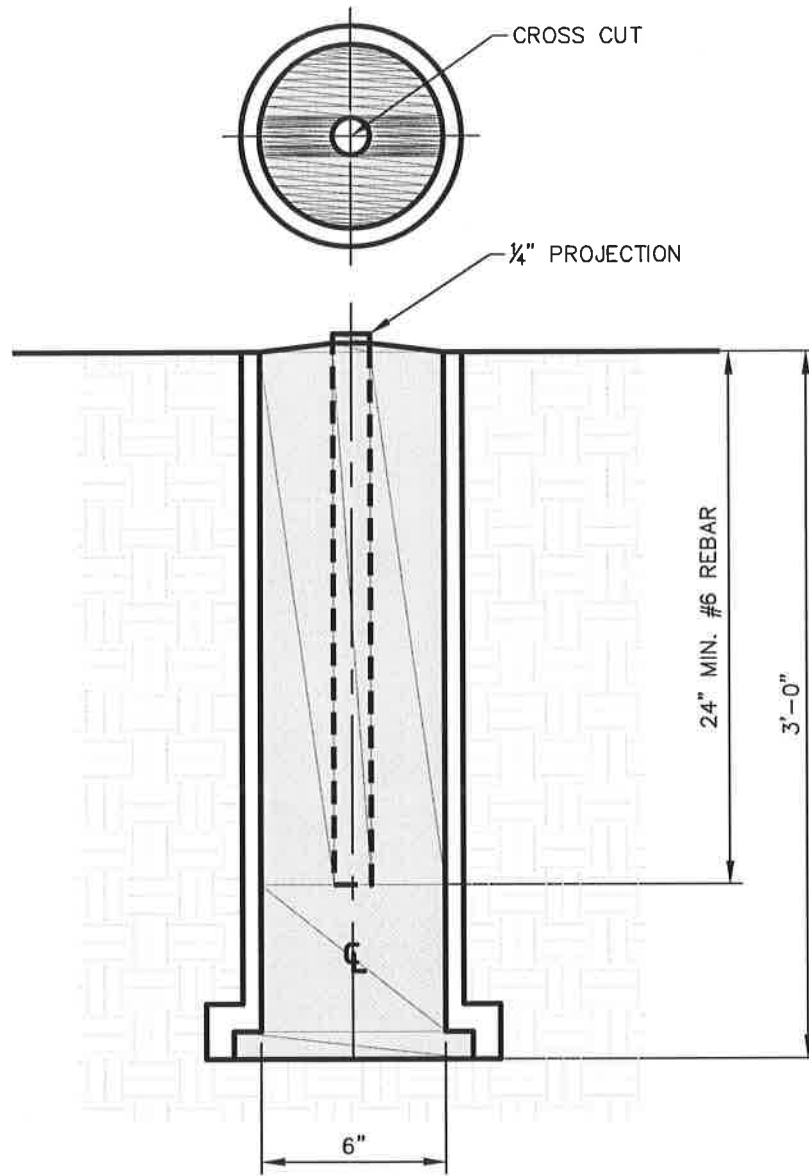

**NOTES:**

1. MONUMENTS TO BE INSTALLED IN SUBDIVISIONS AT DESIGNATED LOCATIONS WITHIN THE STREET RIGHT-OF-WAY 5'-0" OFF THE PROPERTY LINE.
2. 6" CLAY OR PLASTIC PIPE TO BE FILLED WITH CLASS "B" CONCRETE.



## SURVEY MONUMENT DETAIL

REVISIONS				DRAWING
NO.	DATE	NO.	DATE	<b>SD-036</b>